

ELECOMP CAPSTONE SYMPOSIUM
THURSDAY, DECEMBER 19, 2024

THE UNIVERSITY OF RHODE ISLAND

THINK BIG WE DO

Market Gap Assessment Tool

Using Artificial Intelligence to predict and recommend actions



Team Members: Zachary Notarianni (CPE), Samuel Raheb (CPE)

Technical Director(s): Kevin Bagley, Prashanth Somu

Project Motivation

The bioengineering field is advancing rapidly, bringing groundbreaking innovations but also challenges in keeping up with emerging trends. Companies and researchers struggle to process vast amounts of data from scientific papers, patents, and regulatory filings, often missing critical opportunities. This project leverages AI to address these challenges, offering predictive insights that help organizations stay ahead of technological advancements. By identifying under-the-radar innovations and optimizing existing technologies, the platform will provide a competitive edge in recognizing future industry trends. It also supports decision-making in R&D investments, partnerships, and acquisitions, enabling organizations to anticipate market shifts effectively. Beyond competitive advantage, the project contributes to the broader bioengineering field by accelerating innovation, improving healthcare solutions, and enhancing regulatory processes. Ultimately, this initiative aims to empower both companies and the industry at large to thrive in a rapidly evolving landscape.

Anticipated Best Outcome

By the end of the project, we envision a user-friendly Graphical User Interface (GUI) that empowers competitive intelligence teams with advanced AI-driven tools for predictive analysis and research enhancement. This platform will support in-depth investigations into bioengineering technologies, emerging companies, researchers, and innovations, offering a distinct competitive edge. Key features include AI-powered predictive modeling to forecast trends and identify promising technologies, entity extraction to uncover hidden connections and opportunities, and real-time competitive intelligence to monitor market dynamics. With customizable filters, seamless integration with existing research, and an intuitive design, the platform will enable users to make data-driven decisions efficiently and effectively.

Key Accomplishments

- GUI Development:** Developed GUI designs using schematics to help with the planning of the pages. The schematic for the initial search page (Fig. 1) is designed to allow the user to input their query while assigning a specific category of search. The schematic for the results page (Fig. 2) allows the user to see a generalized AI response while also being able to see what the AI used from each source it pulled data from. Also developed an initial fleshed out design for the results page.
- Web Scraping Implementation:** Initiated the creation of multiple web scrapers to automate data retrieval from online sources, enhancing efficiency and reducing manual effort. Our implementations include:
 - Google Search Scraper:** A streamlined scraper that extracts data from Google search results, enabling quick and automated gathering of information based on user-defined queries.
 - FDA Database Scraper:** Developed tools to interact with complex FDA databases, allowing users to input specific queries and retrieve precise, structured data. This functionality is instrumental for research and compliance tasks.
- Dynamic Query Handling:** Implemented advanced functionality in scrapers to adapt to user-inputted queries. This ensures flexibility, allowing the tools to cater to a wide range of search parameters without requiring manual adjustment for each case.
- Scalable Architecture:** Designed the web scraping framework with scalability in mind, enabling the seamless addition of new scraping modules for different data sources as the company's needs evolve.
- Error Handling and Validation:** Integrated robust error handling mechanisms into the scrapers to identify and address issues such as incomplete data, website changes, or unexpected inputs. Validation checks ensure the accuracy and reliability of retrieved data.
- Future-Ready Development:** The tools are built with modularity in mind, ensuring compatibility with future company projects and the ability to integrate additional automation processes without significant overhaul. This also allows for easier troubleshooting during testing.

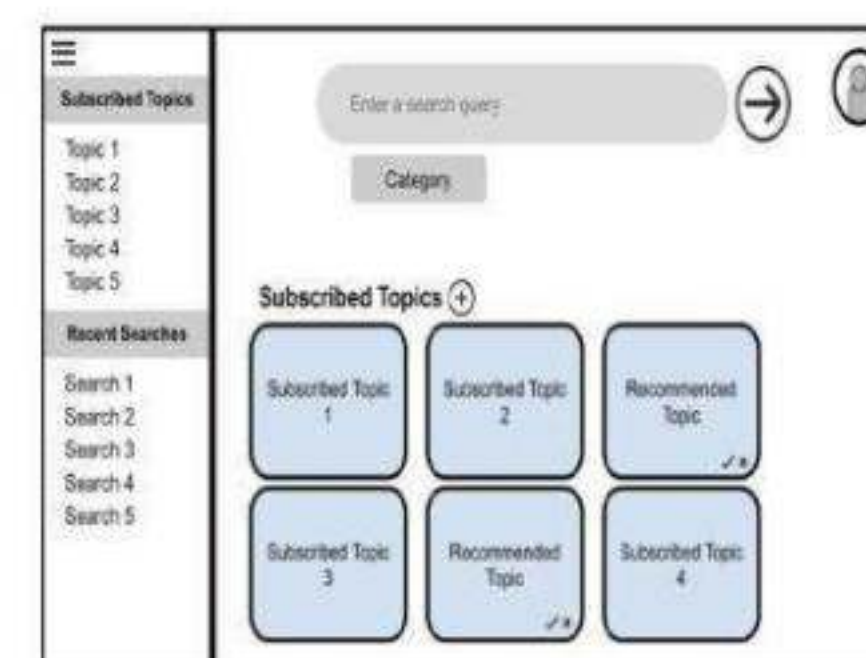

Fig 1: Schematic for initial search page

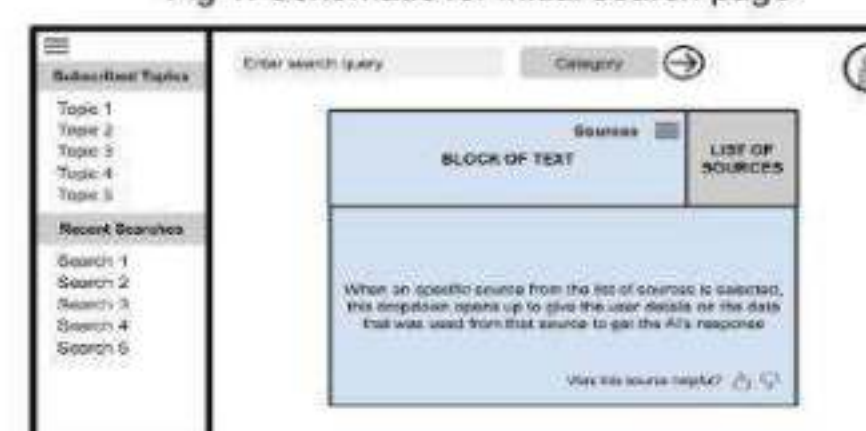

Fig 2: Schematic of results page



Fig 3: First Design of the UI

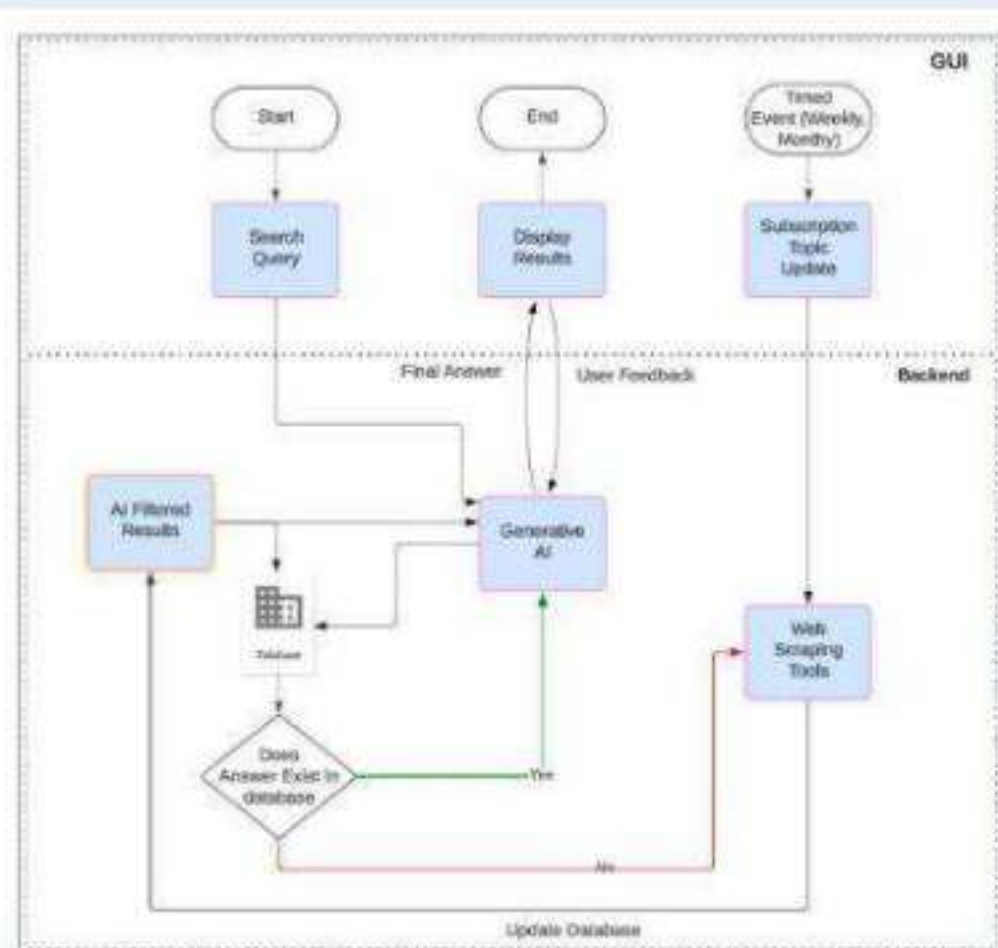

Fig 4: Block Diagram of Project Workflow

Implications for Company & Economic Impact

The successful development of the competitive intelligence tool will profoundly impact Boston Scientific's strategic decision-making, competitive positioning, and innovation capabilities. By the end of the project, the company will gain an advanced AI-powered tool to gather, analyze, and predict trends in the bioengineering sector, providing critical insights for future growth. This tool will enhance competitive intelligence by tracking competitors, startups, and disruptive technologies, enabling proactive responses to market shifts. Its predictive capabilities will optimize R&D efforts, mitigate risks, and uncover emerging trends. Additionally, it will streamline workflows, strengthen innovation, and provide a strategic advantage in mergers and acquisitions, solidifying Boston Scientific's position as a bioengineering leader.

Remaining Technical Challenges

- UI Design and Color Palette Integration :** A key challenge is refining the UI to align with Boston Scientific's designated color palette. This includes adjusting the existing design (Fig. 3) to incorporate consistent branding across all UI elements. Additionally, I must develop a functional button for follow-up responses. This feature will enhance usability by allowing users to refine or extend their queries without starting a new search.
- Initial Search Page Development :** Another challenge is completing the UI for the initial search page. This involves creating an intuitive, visually appealing interface that integrates the Boston Scientific color scheme while remaining user-friendly. This page will serve as the entry point for all user interactions. Incorporating clean layouts and accessible features will ensure a seamless user experience.
- Settings Menu Implementation :** Another technical challenge is designing and implementing a settings menu. The plan involves creating a pop-up interface that blurs the background when opened, ensuring focus remains on the settings. The pop-up will feature a simple close button in the corner and will be accessible from the top-right profile section. This would be used to change certain preferences, as well as managing the user's account.
- AI-Powered Data Filtering :** Leveraging AI to determine which data is worth web scraping is a critical technical hurdle. The system must intelligently identify relevant paths for the user's query, prioritizing high-value information. Implementing algorithms that balance efficiency with accuracy will ensure that the tool generates meaningful insights while avoiding irrelevant or excessive data collection (Fig. 4).
- Query Path Optimization :** In addition to determining data worth scraping, the AI must effectively navigate query paths. Developing an adaptive system capable of identifying logical next steps in the AI's search process will enhance the platform's predictive capabilities. This requires creating robust decision-making algorithms that respond dynamically to user input and search results, ensuring a seamless and efficient research process.

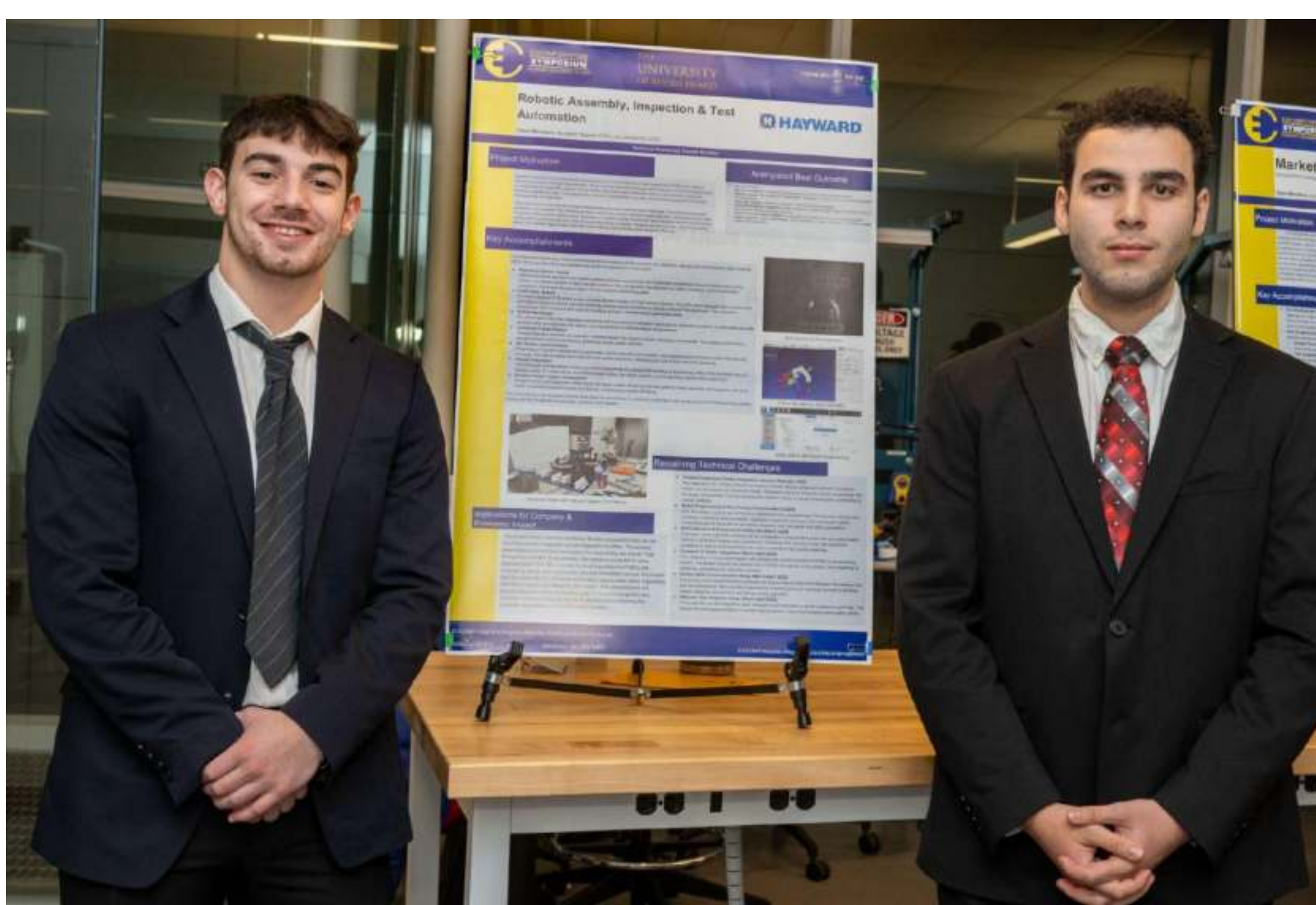

ELECOMP CAPSTONE SYMPOSIUM
THURSDAY, DECEMBER 19, 2024

THE UNIVERSITY OF RHODE ISLAND



Robotic Assembly, Inspection & Test Automation



Team Members: Benjamin Maguire (CPE), Jack DeMarinis (CPE)

Technical Director(s): Russell Buckley

Project Motivation

Hayward Industries' Rhode Island facility manufactures over 100 printed circuit board assemblies (PCBAs) but relies on manual processes for through-hole assembly. These methods are time-consuming, labor-intensive, and prone to errors such as mislabeling and assembly mistakes. Faulty PCBAs often require labor-intensive rework or are discarded, leading to significant operational costs. This highlights the need for a more efficient, accurate, and streamlined approach to through-hole assembly and inspection.

This project aims to automate the through-hole assembly process to address these challenges. The proposed automated workstation will populate PCBs with through-hole components, conduct real-time visual inspections, and log production data to enhance efficiency and quality control. Its flexible and scalable design will allow for easy adaptation across various factory configurations, providing long-term value. By automating these processes, Hayward can reduce errors, improve production speed, and maintain higher quality standards while meeting future manufacturing demands effectively.

Anticipated Best Outcome

- The best outcome is:
- Robot end effector:** Designed for seamless movement of PCBs between stations.
 - Robotic system for component placement:** Supported by a part sorter for precise placement of components.
 - Conveyor system:** Transfers populated PCBs to the soldering station.
 - Automated Optical Inspection (AOI) cameras:** Installed at each station to identify errors in real-time and ensure accurate assembly.
 - Central communication system:** Coordinates all subsystems for synchronized operation.
 - Laser engraver (time permitting):** Adds barcodes or serial numbers to enhance quality control and traceability.

Key Accomplishments

Our project aims to develop a fully automated system for seamless PCB assembly and inspection, aligning with the Anticipated Best Outcome (ABO). Below are the critical accomplishments and their significance to the project:

- Preliminary System Layout:** Utilizing aluminum extrusions and readily available Hayward components, we constructed a preliminary layout to place robotic arms, holders, and feeder systems in their intended positions. This configuration has allowed us to refine workflows, improve subsystem integration, and ensure the layout aligns with the project's overarching goals.
- PCB Feeder System:** A custom-designed PCB feeder system enables efficient transfer of PCBs between stations. The UR3 robot, equipped with a custom-built end effector featuring suction and lever switches, ensures precise handling by detecting secure PCB attachment. This innovation streamlines PCB movement and improves handling accuracy, addressing key operational needs.
- PCB Holder Design:** The 3D-printed PCB holder integrates seamlessly with the aluminum framework and supports adaptable workflows. Its removable standoffs facilitate quick reconfiguration for testing, ensuring flexibility for iterative design improvements.
- Component Feeder System:** Through extensive research, we selected a vibratory feeder from Asyrl to handle challenging components. The ongoing customization ensures efficient and precise delivery, enhancing overall system reliability.
- AOI System Implementation:** Integrating an OpenMV camera into our automated optical inspection (AOI) system, we programmed the fixture to verify PCB assembly accuracy. This step is vital for error reduction and quality assurance, addressing our goal of high assembly standards.
- Robotic Integration:** The UR3 robot and Mecademic Robot have been programmed for precise PCB handling and positioning. With GPIO-controlled vacuum systems, static IP configurations, and Python-based coding, the robotic system ensures optimized, synchronized automation.
- Vibratory Feeder System Development:** Designed and implemented with ERM motors, the feeder system efficiently channels parts for robotic assembly. Its integration with a bin feeder enhances component sorting and delivery, contributing to system efficiency.

This comprehensive development timeline showcases our commitment to achieving a seamless, high-quality automated PCB assembly system, meeting the ABO's goals for functionality, precision, and reliability.

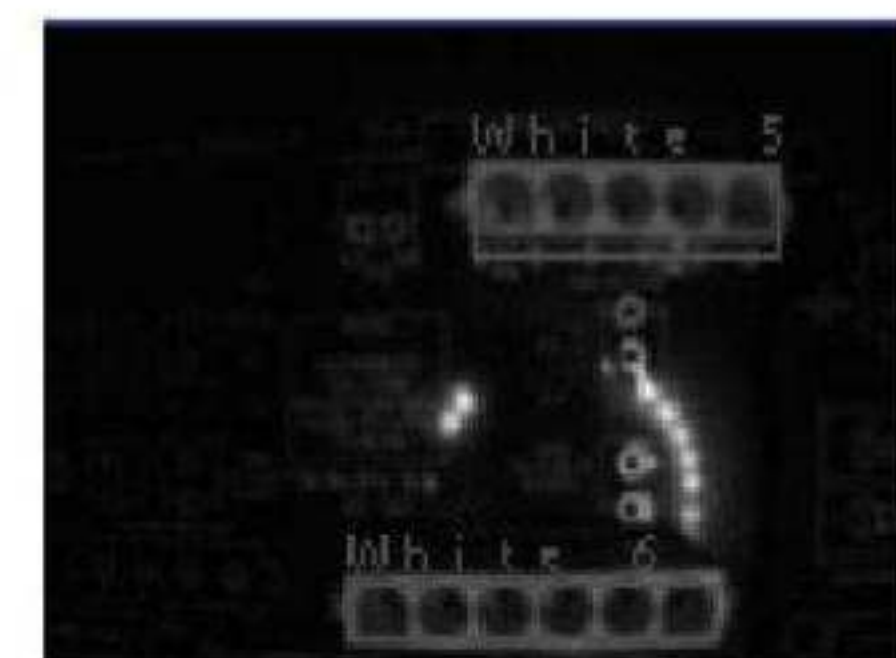

AOI Camera for Part Detection

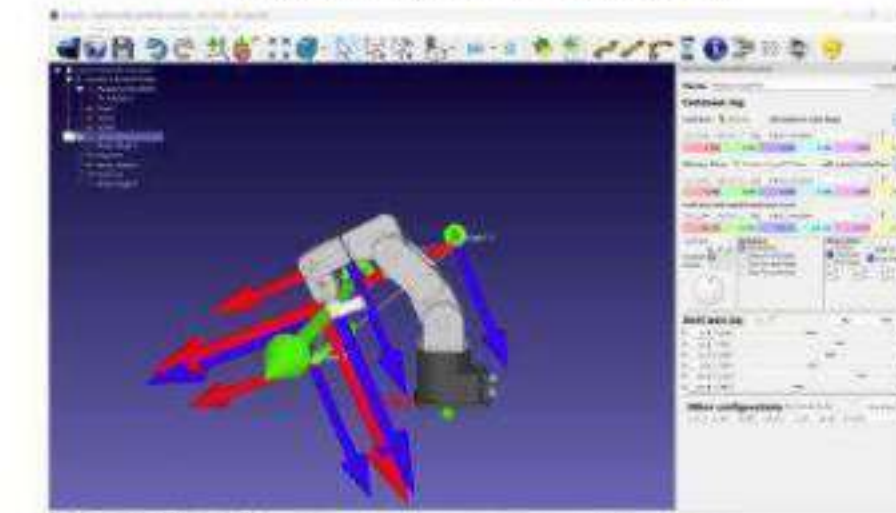

Online Mecademic Robot Simulator



Online IDE of UR3 Robot Programming



Universal Robot with Vacuum System End Effector

Implications for Company & Economic Impact

The project's best outcome will deliver flexible subsystems that can be reconfigured and integrated across Hayward's facilities. The primary deliverable is a functional workstation for assembling the critical 'Field Wiring Panel' PCBA. Economically, the system is expected to save approximately \$120,000 annually by reducing defective PCBAs and minimizing rework and scrap costs. Beyond immediate savings, the project lays the groundwork for broader automation opportunities within Hayward's operations, enhancing efficiency and quality. This advancement will provide Hayward with a competitive edge in the pool equipment and industrial markets, ensuring long-term benefits and positioning the company as a leader in manufacturing innovation.

Remaining Technical Challenges

- Finalize Component Feeder Integration (January-February 2025)**
The integration of a vibratory feeder is crucial to ensure precise component delivery. During this phase, we will acquire and install the feeder, followed by rigorous testing to ensure compatibility with the target components. This will enhance the system's ability to handle diverse parts, contributing to overall reliability.
- Robot Programming & Fine-Tuning (February-March 2025)**
With the feeder in place, we will focus on advanced robot programming. This involves refining pick-and-place routines to ensure reliable, repeatable placement accuracy. Fine-tuning the robot's movements will be essential for seamless interaction with the feeder and other subsystems.
- AOI Calibration & Enhancement (February-March 2025)**
Calibration of the OpenMV cameras will be undertaken to ensure the system can accurately detect different component shapes and orientations. Validating AOI accuracy under real production conditions is vital to minimize errors and ensure consistent high-quality assembly.
- Conveyor & Solder Integration (March-April 2025)**
The installation of a conveyor system will facilitate the smooth transition of PCBs to the soldering station. This phase ensures the physical flow of PCBs through the entire system, from assembly to soldering, completing the assembly process.
- System-Wide Communication Setup (March-April 2025)**
Developing robust communication protocols will ensure smooth interaction between the desktop GUI and the subsystems. This includes implementing threading and error-handling routines to enhance system reliability and minimize disruptions during operation.
- Optional Laser Engraver Setup (March-April 2025)**
If time permits, we will integrate a laser engraver to add barcodes or serial numbers to the PCBs. This feature will link engraved data to a central logging system, improving traceability and quality control.

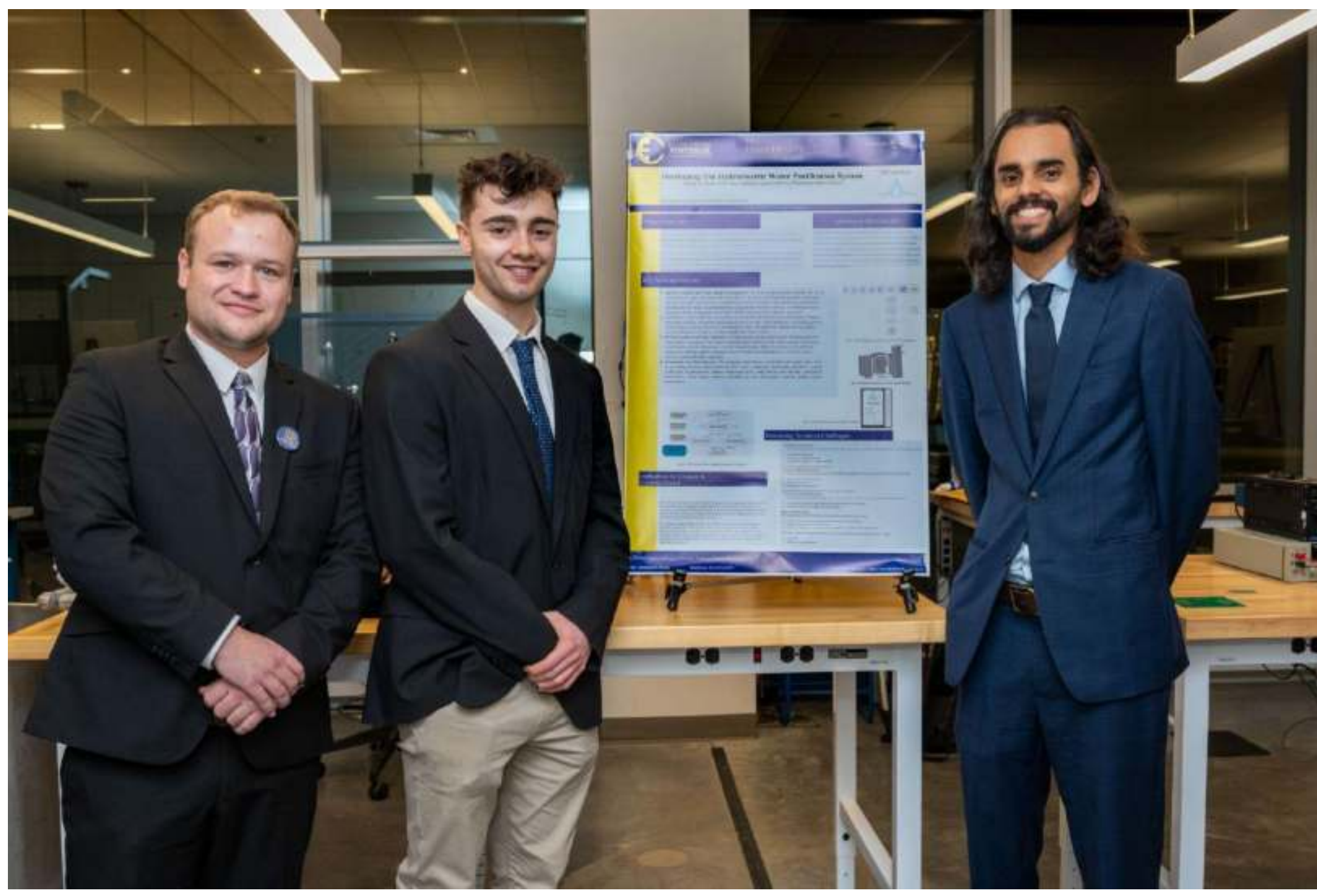

ELECOMP CAPSTONE SYMPOSIUM
THURSDAY, DECEMBER 19, 2024

THE UNIVERSITY OF RHODE ISLAND



Developing The Hydroelectric Water Purification System

Making the Hydro Electric Water Purification System (HWPS) a Whole-Home Market Solution.



Team Members: Michael Marsella (CPE), Aaron Phare (EE)

Technical Director: Alexander Tompkins

Project Motivation

What truly distinguishes the residential HWPS is its integrated hydroelectric power generation. Beyond purifying water, the system generates clean, renewable energy, helping offset household energy costs during operation. This dual-purpose innovation makes it both an environmental and economic asset, offering sustainable solutions that benefit both homeowners and the planet.

Remedion's approach extends beyond water purification—it is part of a broader commitment to remediating pollutants in both food production and water purification through cutting-edge, sustainable technologies. By advancing solutions that address the fundamental needs of clean water and energy, we aim to enhance individual well-being and contribute to global sustainability. Our goal is to make this innovative technology accessible to all, driving progress in both public health and environmental stewardship.

Anticipated Best Outcome

The ideal outcome for this project is the successful development of whole-home Hydroelectric Water Purification System (HWPS) models, which would revolutionize access to clean, safe water for households. By ensuring tap water is free from harmful contaminants, this system will significantly improve water quality, providing families with the peace of mind that comes from pure, reliable water. In addition to enhancing water safety, the HWPS will generate hydroelectric power, leading to lower energy bills and contributing to a more sustainable future. This innovation addresses the critical need for clean water access, making a lasting impact on both health and energy efficiency.

Key Accomplishments

- Battery, Turbine, and Water Pump Specifications:** Our initial design planned to maintain 100 psi of water pressure using a pre-stage water pump (Fig. 1). However, we refined the approach to leverage standard municipal water pressure, simplifying the system operation while maintaining performance. By analyzing the energy extraction potential of discharged water via a turbine, we optimized battery capacity to bridge energy gaps, ensuring the HWPS remains as self-sustaining as possible.
- 3D Model:** Using SolidWorks, we created a 3D model (Fig. 2) that has been instrumental in shaping the project's design. This model visualizes each filtration stage within dimension constraints, guiding crucial design decisions. Beyond its developmental value, this model was shared with our custom steel manufacturers to assist us in fabricating the first market-model.
- In-Line Sensor & Software Selection:** To ensure precise monitoring of system health and purified water quality, we selected TDS (Total Dissolved Solids) sensors for their high accuracy in detecting contaminants and cost-effectiveness. For the companion app, Flutter was chosen as the software framework, offering seamless integration across iOS and Android platforms to deliver a robust, efficient, and user-friendly experience.
- Companion App Development:** The companion app features a dedicated water quality page (Fig. 3), providing real-time metrics from the TDS sensor. Additional functionality includes a system health page for performance updates, maintenance alerts, usage history, and cartridge replacement notifications. These features enhance reliability and user convenience, ensuring optimal system performance.

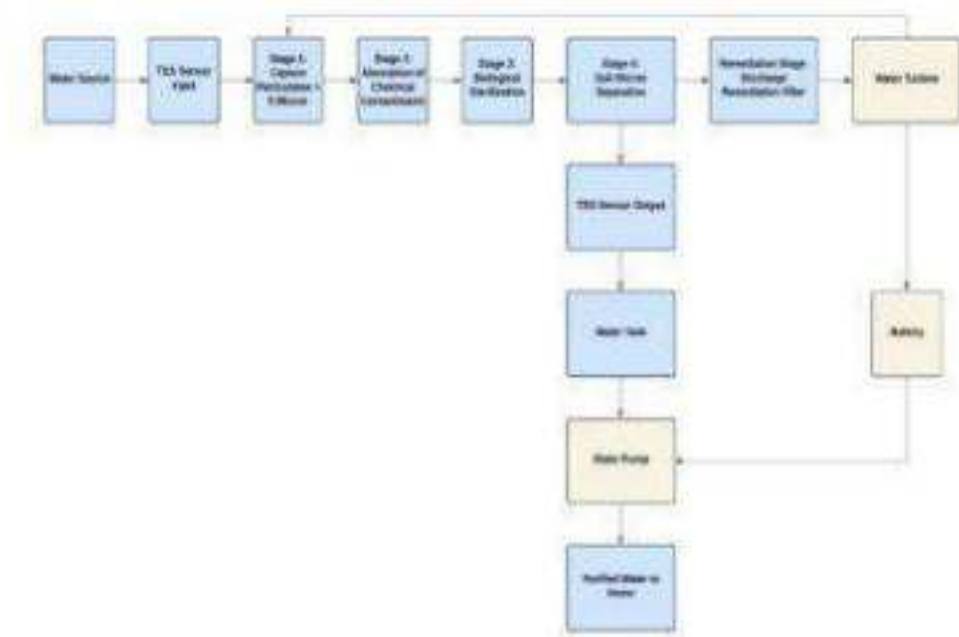

Fig 1: Block Diagram of Current HWPS Development



Fig 2: Initial Solidworks 3D Developed Model



Fig 3: Initial Water Quality Page UI Design

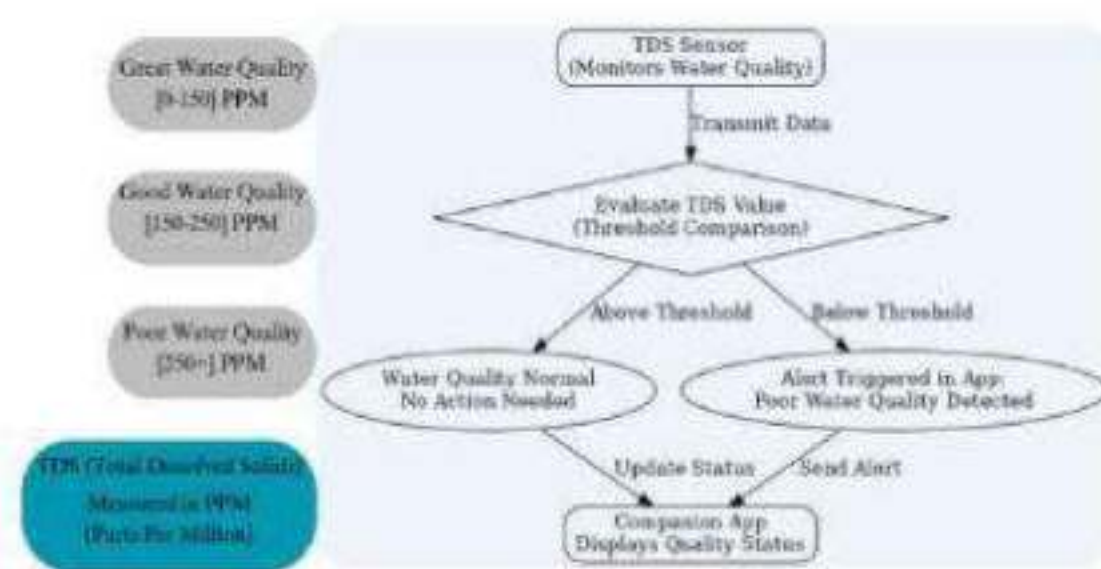

Fig 4: TDS Sensor Water Quality Extraction Flowchart

Implications for Company & Economic Impact

The successful deployment of residential HWPS units will mark a significant milestone for the company and deliver meaningful economic benefits. For the company, the success of this innovation will establish Remedion as a leader in the water purification and renewable energy markets. Beyond initial sales, recurring revenue from replacement components will provide a robust financial foundation for long-term growth.

For consumers and the broader economy, the HWPS offers substantial value. By reducing household energy bills, it increases disposable income and promotes financial stability. Improved access to clean water directly supports better public health outcomes, potentially lowering healthcare costs and enhancing productivity across communities. This project has the potential to generate a ripple effect, creating social, health, and economic benefits on both micro and macro scales.

Remaining Technical Challenges

Finalized App Development:

Key app development tasks include implementing the secure login system and customer support page. These features will provide users with:

- A personalized experience.
- Easy access to support resources.
- The ability to manage their accounts securely.

This ensures a seamless and user-friendly interface.

Interactive HWPS User Interface:

Developing an intuitive physical interface for the HWPS that integrates with the app is essential. This interface will provide:

- Direct access to water quality data.
- System health updates.
- Maintenance alerts and updates.

Users will be able to monitor and manage the system locally and remotely.

TDS In-Line Sensor Implementation:

Integrating TDS sensors into the HWPS is critical for capturing accurate, real-time water quality data. The sensors will:

- Transmit information to the app, allowing immediate detection of contaminants.
- Ensure the highest safety standards for drinking water.

Market-Model Production:

Following production, the HWPS market-model will undergo rigorous testing to ensure:

- Consistent water purification, energy generation, and delivery performance.
- Reliable maintenance of optimal flow rates.
- Effective removal of forever chemicals and microplastics, guaranteeing clean and safe water.

Additionally, seamless integration of the sensors, turbine, battery, and water pump will be a priority to ensure:

- Scalability.
- Efficiency in mass production.

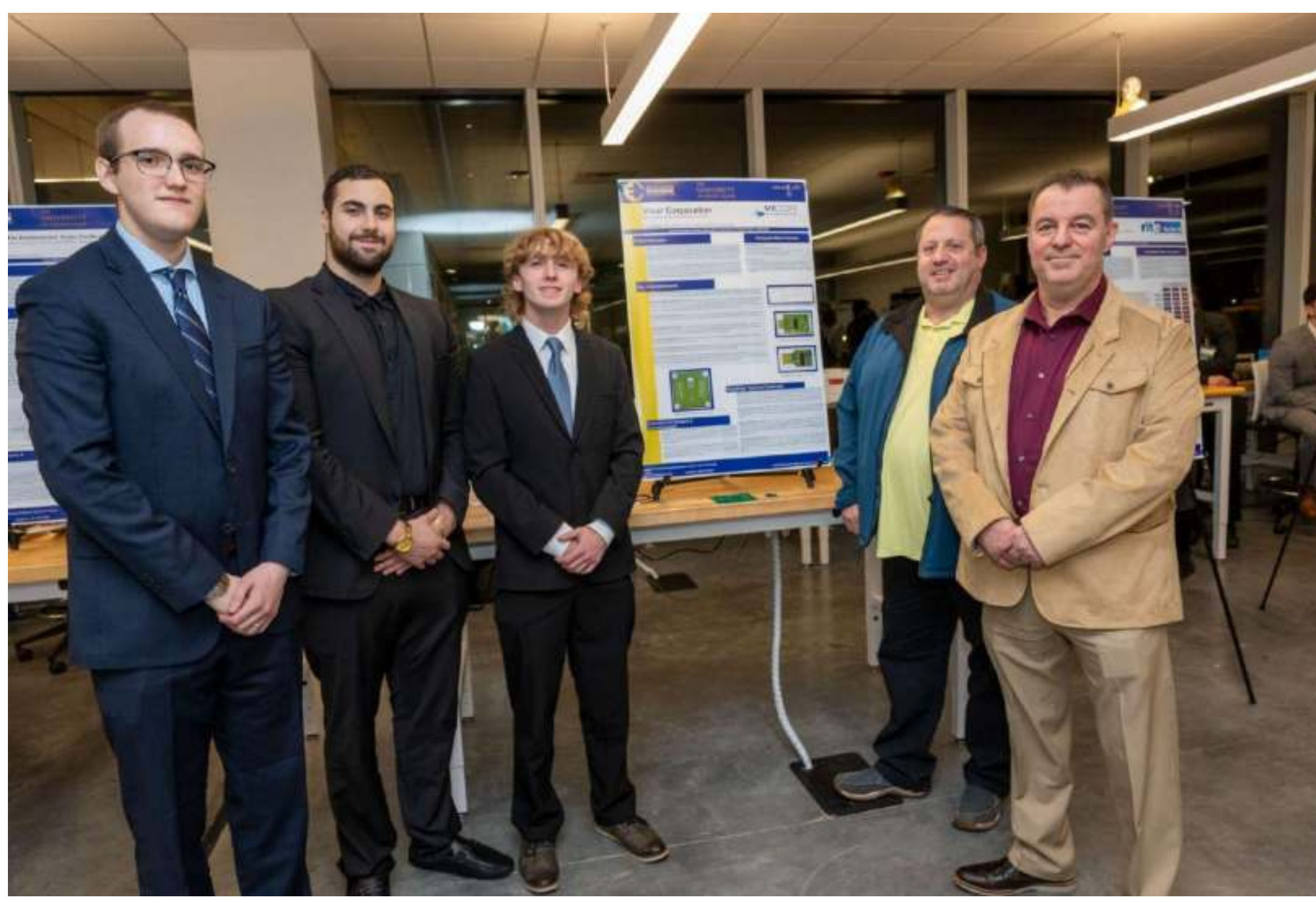

ELECOMP CAPSTONE SYMPOSIUM
THURSDAY, DECEMBER 19, 2024

THE UNIVERSITY OF RHODE ISLAND

THINK BIG WE DO™

Vicor Corporation

GPIB Command Library and CBIT Expander Card



Team Members: Liam Crisfield (ELE & CPE), Andrew Langille (ELE), Gianni Biondi (ELE)

Technical Director(s): Al Binder, Nathan Shake, Daniel Hartnett, Kristopher Keeble, Joshua Hoyle

Project Motivation

The main motivation for Vicor's projects this year is aiming to make the company's die testing more efficient in its edge testing as well as increase Vicor's current Automated Test Equipment(ATE) accuracy. The GPIB Command Library accomplishes this by automating the testing for these wafers outside of the Automated Equipment with a power supply and multimeter. The command library will be able to fully control and run tests, saving time and allowing for an increased accuracy in the test.

The I2C CBIT Expander Card aims to increase the amount of resources Vicor's ATE can use. Vicor's test equipment uses CBITs to increase their devices test limitations however these relay controllers need to be controlled by the resources from within the ATE which are limited. This causes systems to get more complex and need more resources to be tested. To remedy this issue a card must be made to provide the system with more resources to control CBITs.

Anticipated Best Outcome

GPIB Command Library

- Multimeter configuration commands
- Take and store measurements in Eagle Test Systems Software
- Power Supply output configuration and control

CBIT Expander Card

- Creation of 2 PCBs which will increase the ATE's available CBITs by 16
 - 1 Vertical form factor & 1 Horizontal form factor
- Design and creation of a daughter board to test the CBIT Expander Cards

Key Accomplishments

Power Supply GPIB Commands: All functions involving controlling a power supply over a GPIB connection have been completed. These functions include setting a desired voltage, current clamp as well as enabling and disabling output.

Multimeter GPIB Commands: All functions used to set and take readings on a multimeter through a GPIB connection have been completed. This includes functions to set the type of measurement, such as measure voltage, measure current, measure resistance and measure capacitance. Additionally, functions have been created to take multimeter readings based upon the set measurement type and store the measured values in a set test log.

GPIB Command Test Functions: Test functions have been created utilizing all functions created. These functions were used as proof to display the functionality of our code when implemented into the testing environment which will be used.

CBIT Expander Card Schematic: The CBIT Expander Card has been designed to increase the amount of resources available to Vicor's Automated Testing system. The board's schematic was provided by the Vicor team and has been edited to decrease the number of CBITs provided to 16 as the Vicor team desired.

Vertical CBIT Expander Card: The vertical CBIT Expander Card has been completely laid out based upon the CBIT Expander Schematic and traces have been set.

Horizontal CBIT Expander Card: The horizontal CBIT Expander Card has been completely laid out and traces have been set. This board has the same functionality as the vertical card in a different form factor.

CBIT Expander Daughter Board: To test the functionality of the CBIT Expander Card we have decided to create a daughter board which will connect the load board and the two Expander Cards. The board will use 16 LEDs to test all 16 CBITs on a card. The schematic, PCB layout and tracing for this board has been completed.

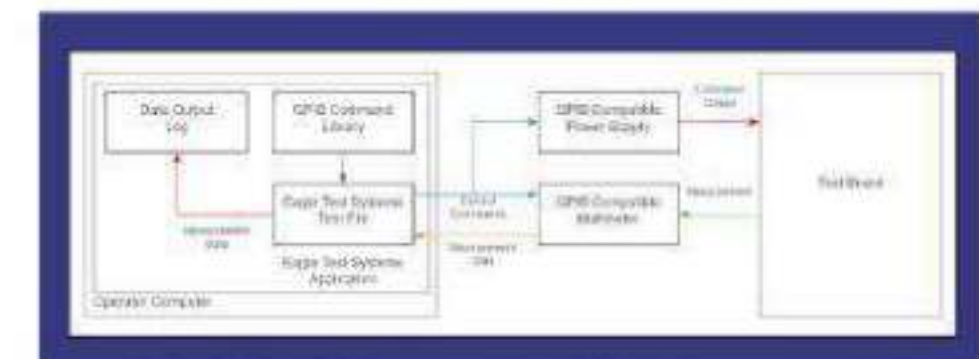

Simplified Block Diagram for GPIB Command Library

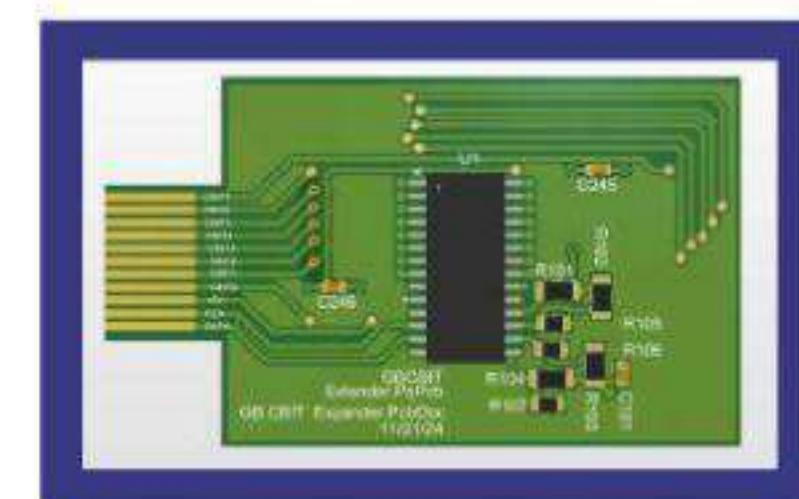

Vertical CBIT Expander Card Layout

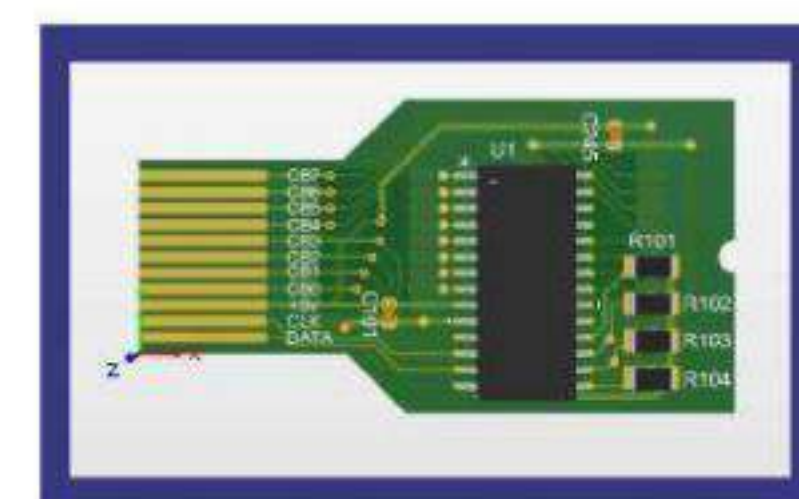

Horizontal CBIT Expander Card Layout

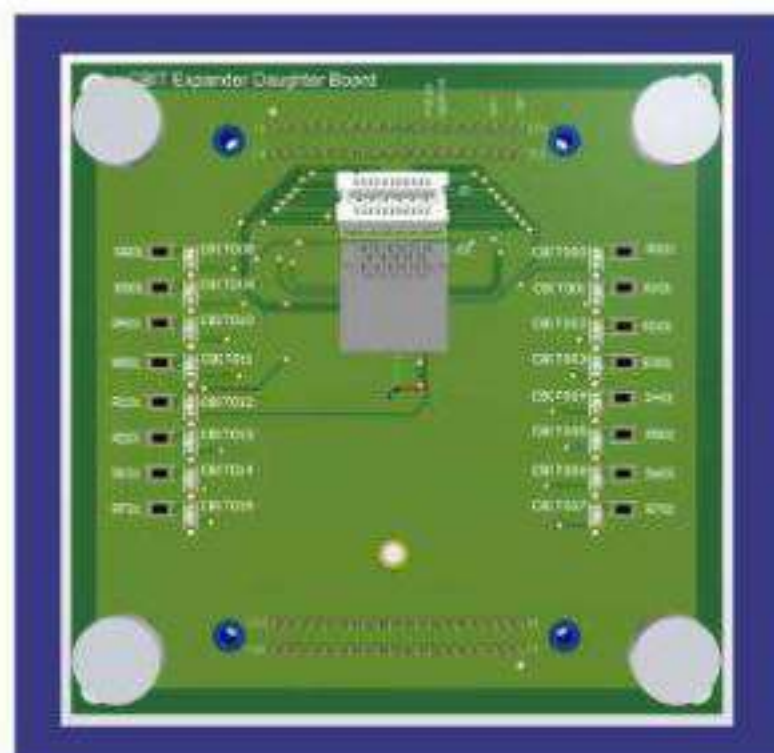

CBIT Expander Daughter Board Layout

Implications for Company & Economic Impact

The GPIB Command Library will allow the testing team to have more accuracy and edge cases in their testing. By providing commands to read and control voltages and currents the team will be able to implement and automate more precise tests with their ATE environment, improving the accuracy of their tests while saving time.

The second part of our project, the CBIT Expander Card will allow for the team to control more CBITs, giving their ATE more resources to use in their testing. This will allow for more complex systems to be developed which is important as the demands of testing become more complex.

Remaining Technical Challenges

PCB Card Build: As our team nears completion of the full design and lay out of our PCBs we must begin to think about building the cards. The actual board will need to be ordered as well as all of the individual components. Throughout our design we have tracked the availability of the components to ensure we will be able to purchase them when needed. After we receive the components our team will be responsible for soldering the parts in their appropriate spots as well.

Adapt CBIT Expander Code: After our CBIT Expander Boards have been created a software customization will need to be implemented to allow the devices to communicate with Vicor's ATE. The base code for this communication will be provided by the Vicor team which we will then modify.

Board Functionality Testing: Once our boards are fully created we will need to test the functionality of our CBIT board designs. This is the purpose of the daughter board which will act as a test for all of the CBITs. Once all boards are plugged into the load board as displayed in Fig 1 we will be able to use the LEDs on the daughter board as a visual test for all 16 CBITs coming from the expander card.

CBIT Expander Documentation: The final step in completion of this project is to create a report documenting the CBIT Expander Card and our testing system. The report should detail the schematic of the expander card as well as how to use our daughter board to test the cards to ensure they are functioning. Upon the completion of this report our project will have reached its ABO.

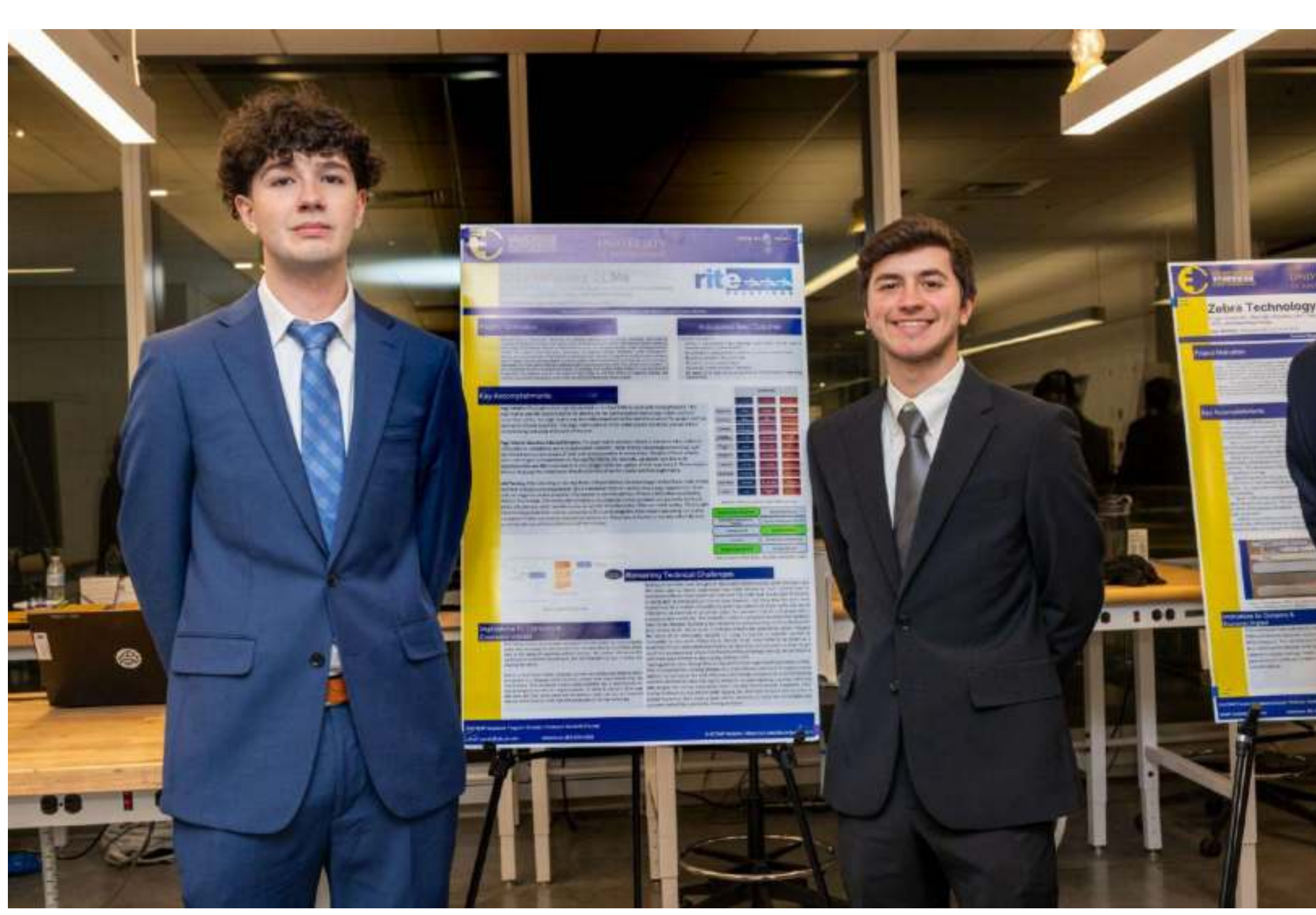

ELECOMP CAPSTONE SYMPOSIUM
THURSDAY, DECEMBER 19, 2024

THE UNIVERSITY OF RHODE ISLAND

THINK BIG WE DO™

On-Premises LLMs

Using Local Large Language Models (LLMs) to aid Java and Rust Software Development, Automated Testing, and Software Reviews

Team Members: Logan Richards (CPE), Damien Lee (CPE)



Technical Director(s): John Sullivan, Alexander Moulton, and Thomas Santos

Project Motivation

Rite-Solutions is continually improving its software development processes, practices, and tools to increase individual and team productivity while improving product quality, decreasing time to market at lower cost. Of particular interest to Rite-Solutions is the use of open source, Large Language Models (LLMs) that support the automated generation of software design, interfaces, code development, testing, and documentation. Rite-Solutions develops and maintains a significant body of Java software used in legacy and on-going projects. Looking forward, Rite-Solutions envisions the use of more modern languages such as Rust to address software safety challenges associated with safety critical systems. A key impediment to the automated generation of software and related digital artifacts in our environment is security. Our desired solution will need to host LLMs on premise where our security policies and controls can protect proprietary and/or other sensitive software and digital assets.

Anticipated Best Outcome

- The best outcome is :
- Deliver a containerized large language model which can be used to translate legacy C++ code into Rust
 - Be proficient in code generation based on a prompt or block of code
 - Be able to generate in Rust and Java
 - Be able to run on a regular laptop
 - Not use any outside sources or packages.
 - Be based on an open source model and will be fine tuned to meet these requirements

Key Accomplishments

Pugh Matrix: The pugh matrix logically decided on the best LLMs to work with moving forward. This pugh matrix was the deciding factor for which LLM the team would be fine tuning in the months to come. Due to this, the pugh matrix was incredibly important to the overall success of the project and has taken a lot of time to perfect. The pugh matrix gave us three viable options for which LLM we will be containerizing and using at the end of the year.

Pugh Matrix Selection Criteria/Weights: The pugh matrix selection criteria is based on what makes an LLM viable for completing our anticipated best outcome. These criteria included parameter size, LLM benchmark scores, last update of LLM, and context window to name a few. Weights of these criteria were used to give an importance to the specific criteria. For example, parameter size due to its importance for our ABO, received an 8 as its weight while last update of LLM received a 3. These weights allow us to gauge the importance of each criteria to allow for a more selective pugh matrix.

LLM Testing: After deciding on our top three LLM possibilities, the team began testing these LLMs to find out their strengths and weaknesses. Since translation from C++ to Rust was a large requirement of our LLM, we began to create a number of programs to test the abilities of these LLMs before any training (RAG or fine tuning). This testing has allowed us to understand what problems will generally be found within all LLMs and which problems may be specific to certain LLMs. After our initial testing, TDs brought other testing possibilities such as asking the LLM to write programs from scratch and asking the LLM to translate C++ with comments and without comments. These tests will allow us to make a final decision on which LLM we will move forward with for training.

	Scoring Key		
	-1	0	1
Parameter Size	< 7 Billion	7-10 Billion	> 10 Billion
Documentation	Base model/sufficient	Base model/sufficient	Little/Not available
Fine Tuning	Sufficient Java & Rust Background	Sufficient Java & Rust Background	Little Java or Rust
Popularity (# of downloads)	> 10,000	5,000 - 10,000	< 5,000
Big Code C++ Score	> 48.45	25.75 - 48.45	< 25.75
Big Code Java Score	> 44.72	24.34 - 44.72	< 24.34
LLM Maturity	> 6 months	3 - 6 months	< 3 months
LLM Last Update	< 2 weeks ago	2 - 8 weeks ago	> 8 weeks ago
Context Window	> 50k tokens	20k - 50k tokens	< 25k tokens
License	MIT	Apache 2.0 or other	Rust/Other

Selection Criteria used for Pugh Matrix scoring

Qwen2.5-Coder-7B-Instruct	Nxcode-CQ-7B-orpo
DeepSeek-Coder-V2-Lite-Instruct	OpenCodeInterpreter-DS-6.7B
CodeGemma-7B	Codestral Mamba
Llama3.2	OpenHermes-2.5-Mistral-7B
Artigenz-Coder-DS-6.7B	Yi-Coder-9B-Chat

LLMs scored by Pugh Matrix (top three highlighted green)

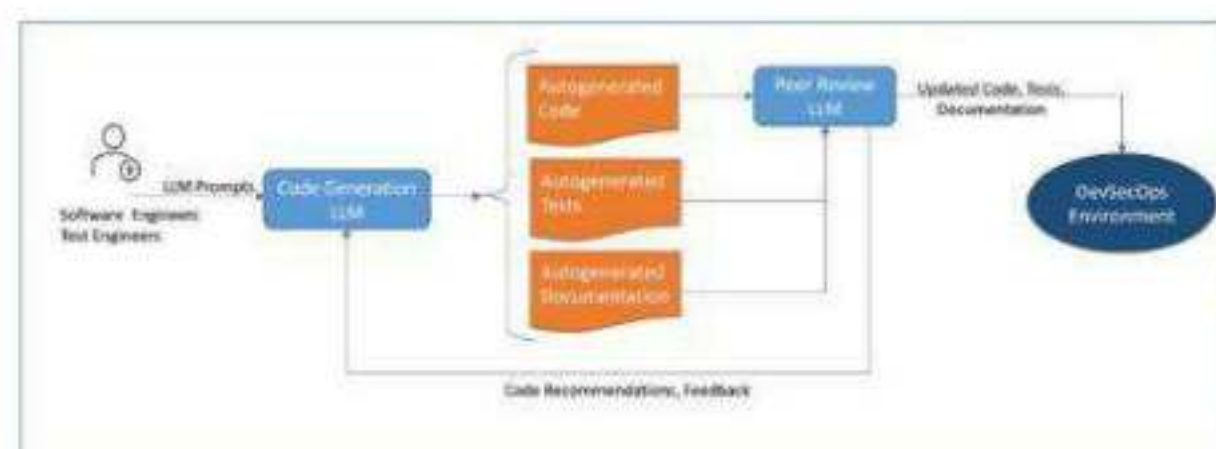

Block Diagram of LLM use

Remaining Technical Challenges

Testing of our LLMs have brought an abundance of information which the team and TDs have used to better understand how LLMs behave at their current level in correlation with our anticipated best outcome. The LLMs have shown a lot of promise in being able to translate from C++ to Rust, however, the three that the team have tested have hit a number of roadblocks which are common in these LLMs and can be inferred to be common in all similar LLMs. For example, Rust as a language uses a property called mutability. This property is given to a variable to allow that variable's value to be changed. Mutability was shown to be a shortcoming to the LLMs that the team tested so far. Many errors in LLM-generated code were either about changing the value of an immutable variable or trying to borrow a mutable variable as immutable or vice-versa. These issues, though small, have come to be shown as a weakness for our LLMs which will need to be taken into consideration. In order to get rid of this weakness and others that have been found through testing, we will need to add these requirements to the training of these LLMs.

Training will be done through fine-tuning and retrieval-augmented generation or RAG. RAG is important for training because it is time effective and doesn't require a large addition to the size of the LLM. RAG uses and changes means such as pre-processing and data retrieval to allow the LLM to be better at understanding a prompt and being able to give the correct information that it already has to answer a question. Fine-tuning implements new data in order to give the LLM more to work with in order to answer a prompt. Both training types will be necessary to reach our anticipated best outcome and will be used in the coming semester.

Implications for Company & Economic Impact

Rust has become a very important language in the DoD space due to its increased ability within the scope of cybersecurity. Java has also become much more widely used in the space of improving software security. Our product will provide the opportunity to accelerate development, test, and integration of Java in legacy and ongoing/new efforts.

Rust is a much more modern language, so there are abilities and features which are specific to a language which has been created much more recently than the normal group. Rust addresses memory safety problems and is recommended for new development as well as in legacy systems. An ability to use our LLM to code with Java and Rust would allow Rite Solutions to utilize the new and improved features without having to fully train their employees on this new technology.

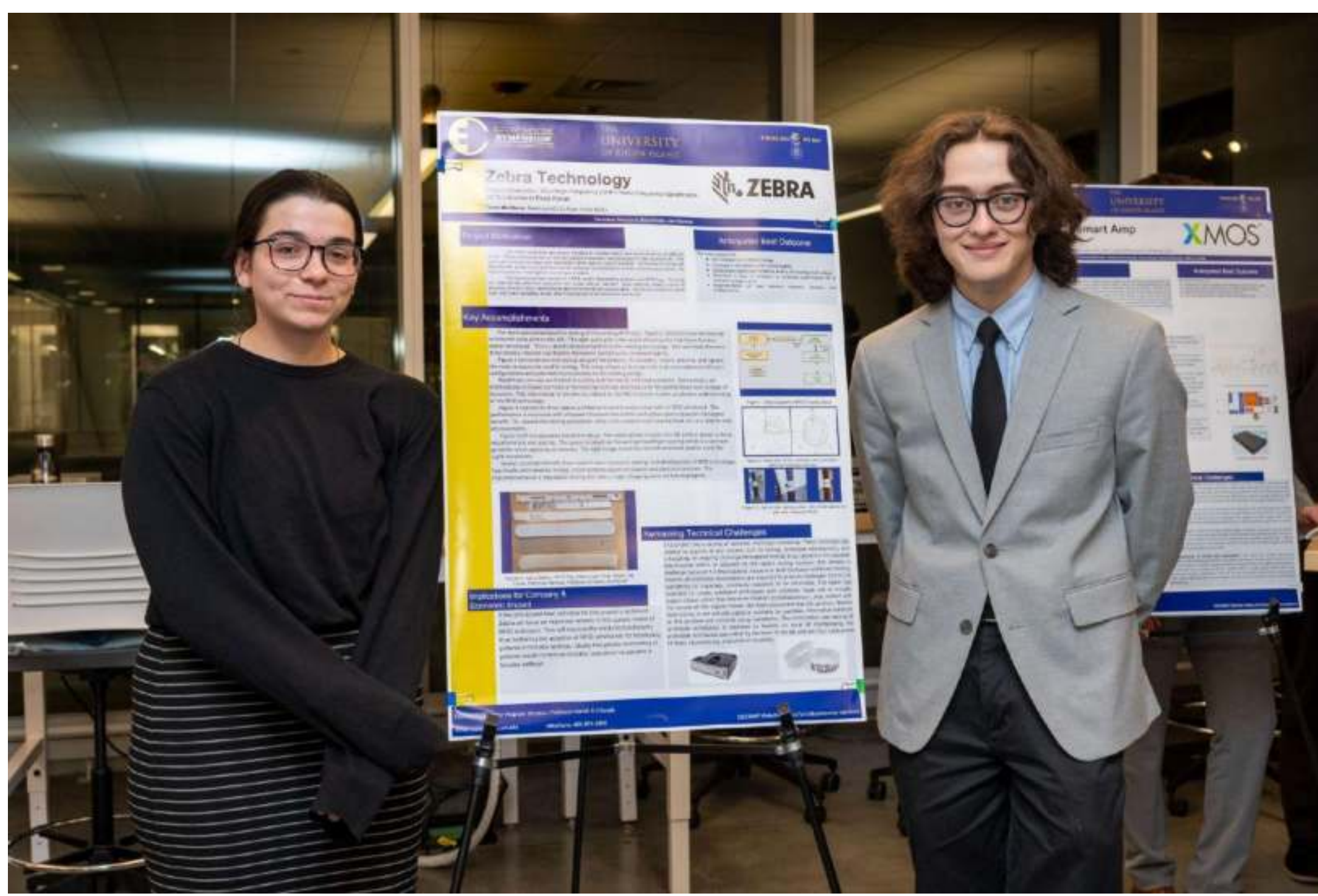

ELECOMP CAPSTONE SYMPOSIUM
THURSDAY, DECEMBER 19, 2024

THE UNIVERSITY OF RHODE ISLAND

THINK BIG WE DO™

Zebra Technology

Project Greenville - Ultra High Frequency (UHF) Radio Frequency Identification (RFID) Wristband Read Range

Team Members: Remi Lloyd (ELE), Ryan Hurley (ELE)



Technical Directors: Gene Hofer, Joe Moreira

Project Motivation

UHF RFID wristbands are used in hospitals to monitor patient and doctor locations in different zones. These wristbands are printed with patient information and barcodes for staff accessibility. The goal is to increase the range and capabilities of the tags to support hospitals. Increasing the range will allow for less power to be used and cost to be saved by reducing the number of antennas required. All tags are passive, meaning they do not have a battery.

The main equipment consists of a RFID reader, transmitting antenna, and RFID tags. The tags are worn on the wrist and respond to the reader with an identifier. Each antenna creates a zone of detection around it which allows the location to be monitored appropriately. Having one antenna in each room and one in a hallway would allow for all people in the area to be monitored.

Anticipated Best Outcome

The best outcome is :

- An increase in wristband range
- Increase in wristband omni directionality
- Statistically significant baseline testing of existing technology
- Reduction in cost of wristband or increased performance for a minimal increase in cost
- Experimentation of new antenna materials, designs, and configurations.

Key Accomplishments

The team completed baseline testing of the existing RFID tags. Figure 2. demonstrates the existing wristbands polar plot on the left. The right polar plot is the result of testing the FabriFoam Nimbus spacer wristband. This is a drastic improvement from the existing technology. Not only does the omni directionality improve significantly the overall performance increased slightly.

Figure 1 demonstrates the testing setup of the process. A computer, reader, antenna, and tag are the main components used in testing. This setup allows us to accurately and repeatedly test different configurations and potential improvements to the existing design.

Rapid tests are also performed to quickly look for trends and improvements. For example, we methodically removed portions of the existing antenna and measured the performance over a range of distances. This information is not directly related to the ABO however it gives us a better understanding of the RFID technology.

Figure 4 represents three spacer wristbands tested in conjunction with an RFID wristband. The performance is improved with all spacers however the middle white/blue spacer provides the largest benefit. Our repeatable testing procedures allow us to compare each new method one at a time to find improvements.

Figure 3 left encapsulates the entire setup. The center photo includes the 3D printed spacer to keep equal tensions and spacing. The spacer is based on the average two finger spacing which is a common guideline when applying wristbands. The right image shows the second wristband used to mark the eight increments.

Overall, accomplishments have been made in research, testing, and development of RFID technology. Specifically with baseline testing, accompanying spacer wristbands and statistical analysis. The implementation of a repeatable testing plan was a major stepping stone for future progress.

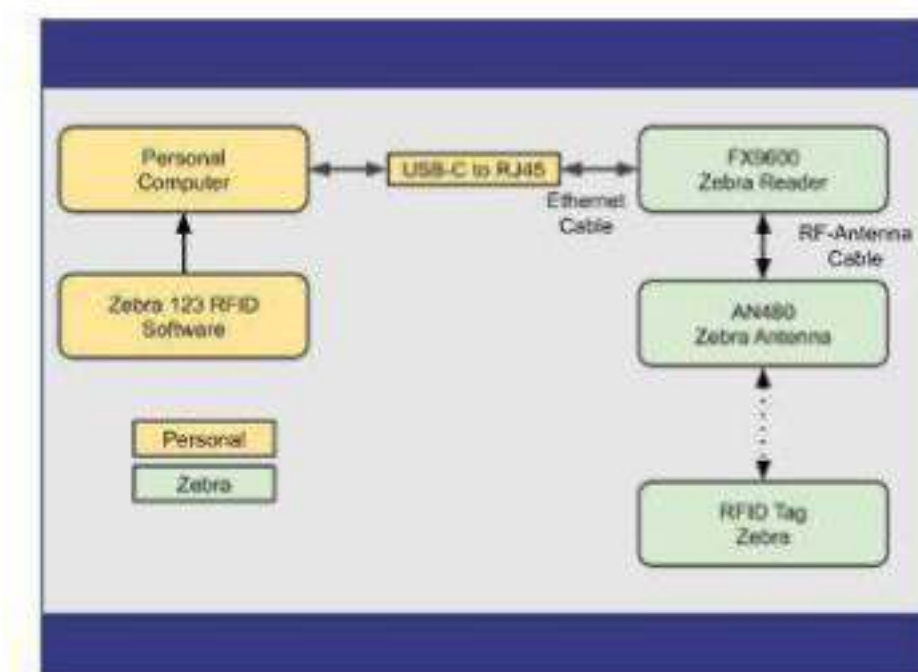

Figure 1: Block Diagram of RFID Testing Setup

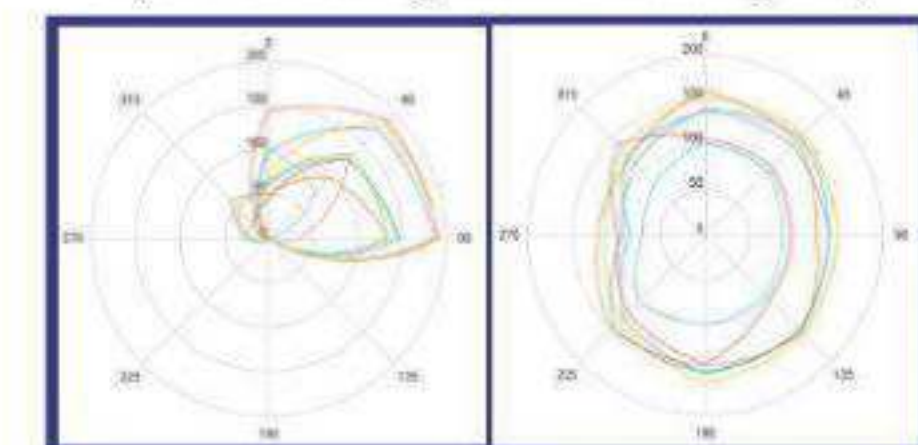

Figure 2: Polar plot of left, wristband only and right, with the FabriFoam Nimbus



Figure 3: Left to right, testing setup, 3D printed spacer on arm, and close-up of arm



Figure 4: Top to Bottom: RFID Tag Antenna and Chip, Plastic Tag Cover, FabriFoam Nimbus, FabriFoam X-Treme, ComfyCuff

Implications for Company & Economic Impact

If the anticipated best outcome for this project is achieved Zebra will have an improved version of this current model of RFID wristband. This will improve the products functionality thus furthering the adoption of RFID wristbands for monitoring patients in hospital settings. Ideally this greater monitoring of patients would contribute to better outcomes for patients in hospital settings.

Remaining Technical Challenges

This project has a variety of technical challenges remaining. These challenges are related to aspects of our project, such as testing, prototype development, and scheduling. An ongoing challenge throughout testing in our project is the possible interference within or adjacent to the team's testing location, this remains a challenge because it is impossible to measure or limit this factor within our testing. Aspects of prototype development are expected to present challenges due to the availability of materials, previously expected to be attainable. The team had intended to create wristband prototypes with antennas made out of metallic copper ribbon rather than the more standard etched aluminum, after contact with the vendor of this copper ribbon, the team discovered that this product, despite their claims, is not actually viable or available for purchase. Alternative solutions to this problem are currently being considered. The construction and testing of prototype wristbands is expected to involve an issue of standardizing the prototype wristbands assembled by the team in the lab and are thus more prone to flaws, inconsistency, and a lack of durability.



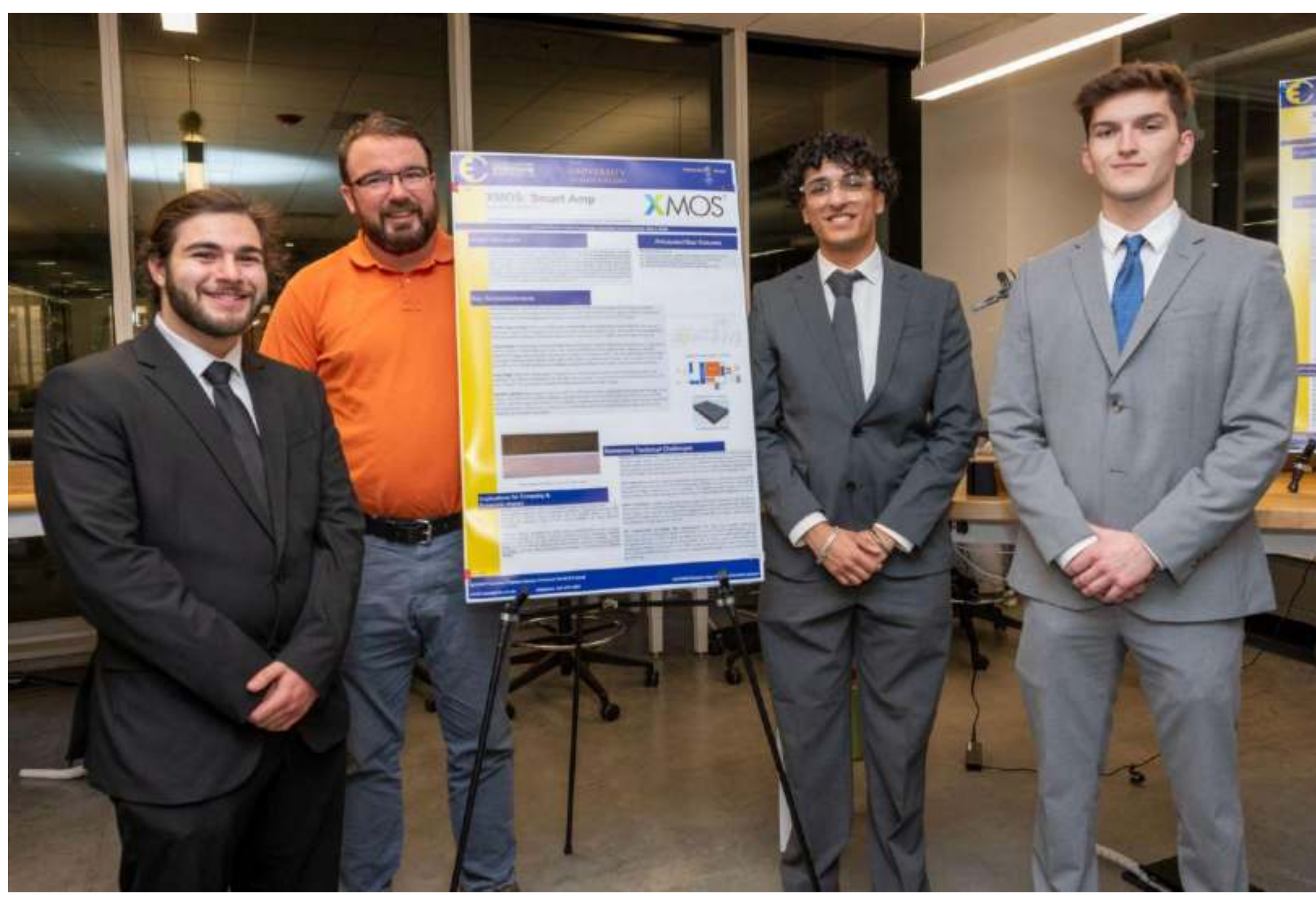

ELECOMP CAPSTONE SYMPOSIUM
THURSDAY, DECEMBER 19, 2024

THE UNIVERSITY OF RHODE ISLAND

THINK BIG WE DO™

XMOS: Smart Amp

Audio DSP on XCORE.AI



Team Members: Ahmad Almuhtaseb (CPE), Sahil Chadha (CPE and ELE), Evan Murray (ELE)

Technical Director: Andrew Cavanaugh | **Consulting Technical Director:** Mike D. Smith

Project Motivation

XMOS processors are well suited for AI, Digital Signal Processing, and control processing, giving the company strong brand recognition in the high-end audio market. Most of its existing applications involve some combination of Analog to Digital/Digital to Analog Converters, USB audio streams, and DSP. That being said, XMOS has not yet created an application which directly acts as a high fidelity audio product like an amplifier or a sound system. With this project, the team wishes to see if the DAC can be removed in order to create a lower cost solution with tighter control over the output sound from the DSP subsystem. This project will also demonstrate the ease of use of Audioweaver from DSP Concepts; if the Anticipated Best Outcome is achieved, then a team of students will have created a prototype audio product (in this case a digital guitar amplifier) in just 7 months.

Anticipated Best Outcome

The best outcome is to:

- Implement a Class D amplifier with software control from an xcore
- Accept input from an instrument. In our case, a guitar pickup
- Implement Digital Signal Processing on xcore.ai
- (Bonus) Play sound from a guitar that never needs tuning

Key Accomplishments

MCAB Schematic: The MCAB has been completely redesigned to fit the needs of the Class-D Amplifier. Components such as the digital-to-analog converter and various unnecessary input connectors have been removed. The XTAG 4 debug system has been removed in favor of an external JTAG device.

XCORE Programming: Code was written and compiled onto our multichannel audio board for future use in the project. Basic xcore programs that pass data over channels between tiles, and produce timing diagrams were successfully created. This will be used for the transmission of our digital data through the board.

Output Stage: A half bridge class-D amplifier was simulated in LTSpice, effectively recovering an input signal. Within LTSpice, a PWM signal generator was made for the input to our gate driver. Using our selected MOSFET the signal was amplified and passed through an LC lowpass filter. The recovered signal on the load accurately replicates the original input signal after about 5 milliseconds of delay. Our simulation shows the feasibility of our design working on hardware, and the confidence we have in our component selection.

Input Stage: With the analog signal coming from an electric guitar pickup, the small signal needs to be amplified. An LTSpice simulation of an Op Amp and a resistor to represent the input impedance of our ADC were created. This simulation showed the effectiveness of our chosen design.

Speaker Cabinet: Both custom made and off the shelf options were explored for the physical housing of our project. The options for speaker cabinets are plentiful and an off the shelf cabinet will be chosen for the project. Should we decide to build one ourselves, considerations such as size, shape, and material will affect the sound quality. Reflex ports contribute a considerable amount to performance as well, and their size needs to be accurately calculated.

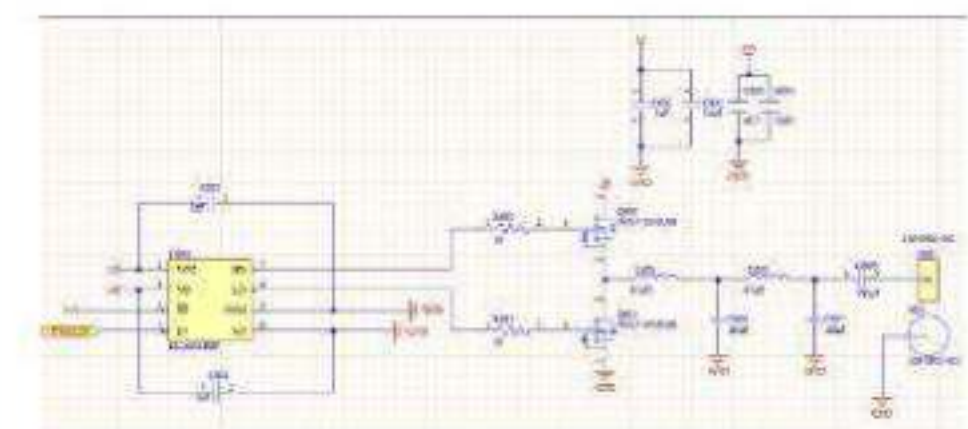

Class-D Amplifier Output Schematic

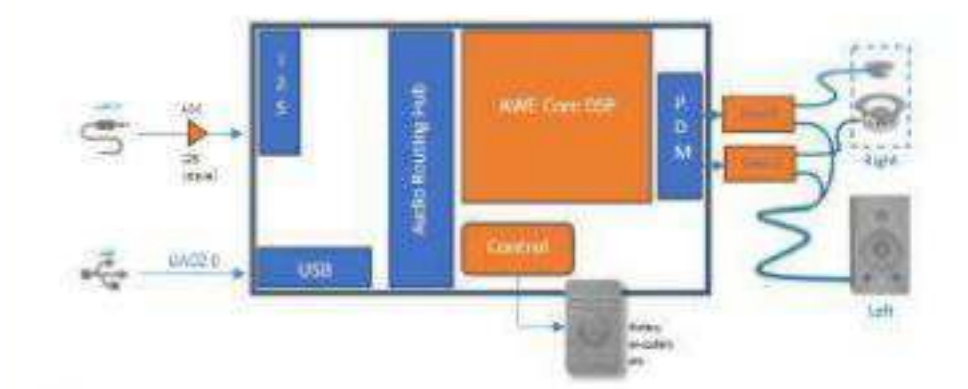

Conceptual Block Diagram

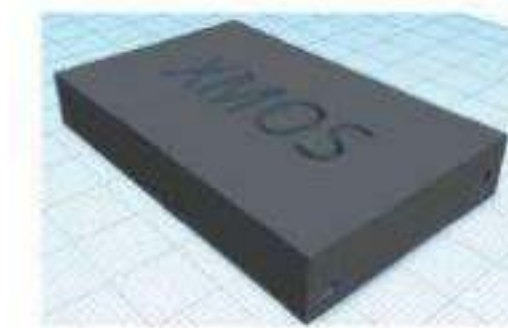

Amplifier Housing Design

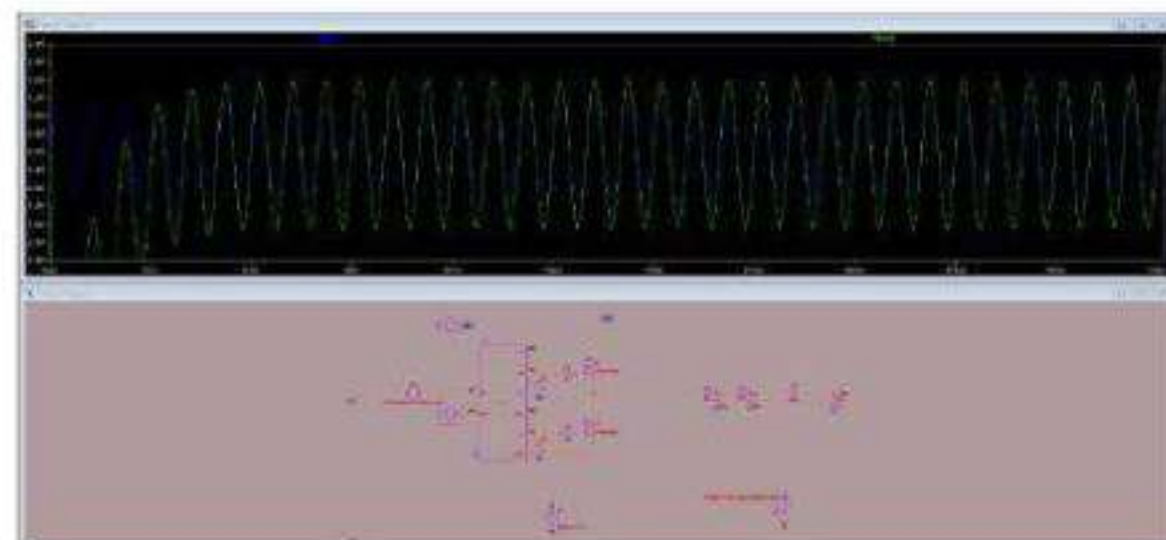

Output Stage Simulation (1 kHz sine wave input)

Remaining Technical Challenges

Guitar and Pickup Selection: A Guitar and guitar pickups must be selected in accordance with the input stage design. The voltage levels must match, and the pickups must use the proper channel system to ensure data will be transferred as predicted. The most likely selection will be the usage of passive pickups due to their cost effectiveness and low voltage ratings (around 400-700mV RMS). This will help to showcase the effectiveness of the input-stage pre-amp.

PCB Preparation: Now that the final schematics are designed, the remaining course of action is to place the new components into the board layout, finalize the new overlays, and order all materials to begin preparing the first prototype. The regions for each stage of the board (input, output, xcore) have already been determined to help simplify the organization process.

PWM in Software: In order for the new output stage to function, the xcore must be able to drive a pulse-width modulated signal through comparing the time-interleaved ADC values to a carrier signal. This solution will have to be recognized as a parallel program that is able to produce the PWM output in sync with the retrieval of data from the digital signal processor and acquisition of new data from the ADC.

DSP Programming on XCORE with Audioweaver: The team has already familiarized themselves with Audioweaver thanks to the delay and reverb modules that function on the multichannel board. In order to create an effects processor similar to a digital guitar amplifier, the board will have to make use of the onboard DSP to create unique audio effects like compression, flangers, and phasers. The DSP can also be used to help restore characteristics of the original signal that are lost in hardware complications through the use of pre-distortion and dithering.

Implications for Company & Economic Impact

Removing the need for a DAC in a standard analog audio product will demonstrate additional cost savings that result from choosing to develop DSP products on xcore.ai. This, combined with the implied ease of use, will increase the perceived value of the xcore.ai platform for many potential customers.

Software defined hardware will allow audio manufacturers to use a single electronic design to service multiple products by only changing software designs and rolling out new features with simple firmware updates. Finally, Audio Weaver's simple interface will allow domain experts in acoustics/music to design products without specialized knowledge of electronics or software design.



ELECOMP CAPSTONE SYMPOSIUM
THURSDAY, DECEMBER 19, 2024

THE UNIVERSITY OF RHODE ISLAND

THINK BIG WE DO™

XBOT

Motor Control on XCORE.ai



Team Members: David Quevedo (CPE), Ean Newman (ELE), Noah Hawkins (ELE)

Technical Director: Andrew Cavanaugh | **Consulting Technical Director:** Chris Rothwell

Project Motivation

The motivation behind the XBOT project is to leverage and showcase the capabilities of XMOS's xcore.ai chips through the development of a sophisticated robotic arm. The xcore is a highly versatile processor designed to excel in real time control and AI applications. Building upon the work of the previous team, this project seeks to refine and enhance a five-axis robotic arm system that integrates voice commands for control. By demonstrating the flexibility of and computational power of xcore.ai chips, the project aims to create a powerful marketing tool for XMOS. Additionally, it also provides a platform for developing robust motor control algorithms, real-time processing, and predictive maintenance. These advancements have potential implications for industrial applications, emphasizing energy-efficient motor control and automation. The ultimate goal is to demonstrate XMOS technological prowess while creating reusable design elements for future deployments.

Anticipated Best Outcome

The Anticipated Best Outcome (ABO) for the XBOT project includes successfully replicating the previous year's robotic arm demo while making significant enhancements. Key targets involve creating an updated PCB with no errors, achieving precise motor control of at least axis using low-level algorithms, and demonstrating object manipulation between two points. Additionally, if time permits, implementing machine learning-based predictive maintenance for at least one subsystem is a stretch goal. Achieving these objectives would demonstrate the xcore.ai chip's capabilities, enhancing XMOS's presence in the motor control market and providing a robust hardware-software reference design for potential customers.

Key Accomplishments

Programming: Analysis of the source code showed the initial status of last year's programs. Allowed for identification of the motors used and was able to run it to recreate the demo from last year. David set up a bash script to automate initialization and set up the environment before coding XBOT.

Motor Control: Motors have been tested and confirmed to all be in working condition meaning we don't need to replace any of them. We have generated a signal using the oscilloscope to show the PWM signal as XBOT runs.

PCB Updates: Analyzed our PCB to make the corrections necessary for the ABO. We added a test point to a level shifter (24v to 5v). We have rerouted the Microphones to the correct tile, tile 1, making it possible to program since the SDK is set up like this by default. We have outlined the addition of a second QSPI flash to ensure memory flashing to both xcore.ai chips independently. Plan to add an additional through hole via for ground to ensure smooth probing and testing of the PCB with an apparatus like the oscilloscope. We also generated a BOM that allowed us to categorize and catalog the parts that are available or needed to be reconfigured or ordered from another source.

Kinematic Configuration: Determined the configuration doesn't rely on an external library but an internally defined class for the mathematical operations. This provides significant flexibility as we have full access to all private members of the kinematics class. This allows for fine-tune controlling of the parameters directly. We will adjust and optimize the robotic arm's movements to better align with our project's specifications and goals. David has outlined a plan to create a separate build environment to test different parameter configurations. Experimentation with various tuning strategies will allow us to optimize the arm's responsiveness and stability.



Fig 1: Five Axis Robotic Arm with Joints Labeled

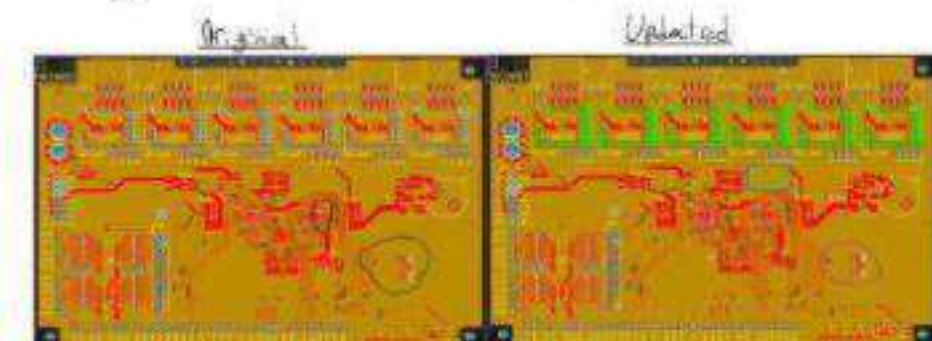

Fig 2: PCB Updates As of December 8th, 2025



Fig 4: Arm PCB + XTAG + Voice Reference PCB + Power Supply Set Up

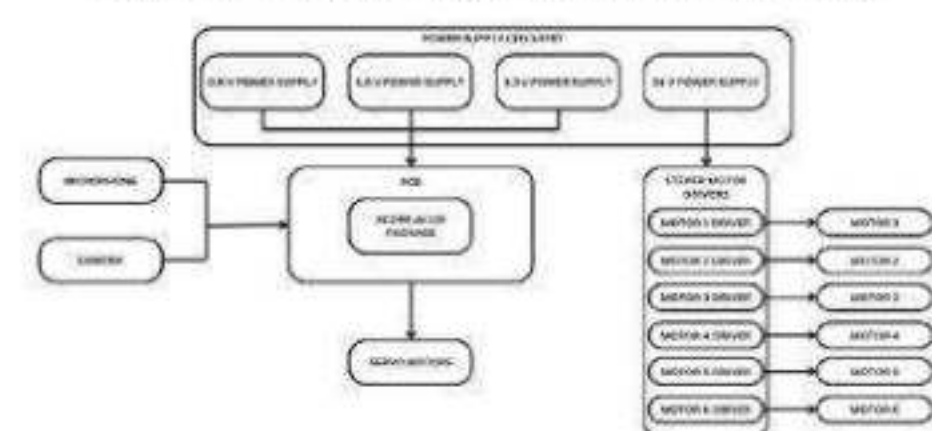

Fig 3: High Level System Block Diagram

Implications for Company & Economic Impact

Achieving the project's goals would position XMOS to expand its presence in the robotics and industrial automation markets by demonstrating the versatility of its xcore.ai chips. This could lead to the rapid adoption of XMOS technology for motor control, opening new revenue streams beyond consumer electronics. The ability to implement energy-efficient control, real-time updates, and predictive maintenance algorithms would appeal to industries looking to optimize operations and reduce costs. The project's outcomes could help XMOS diversify its customer base, making it less reliant on volatile markets while enhancing its reputation as a leader in embedded AI-driven motor control solutions.

Remaining Technical Challenges

Camera Implementation: The ABO for our project includes a demonstration where the XBOT will move an object between two locations. For this to be possible, there needs to be some way for the arm to detect and differentiate between different objects. Our team has decided that a camera would be the most effective sensor to use to assist in object detection. One challenge that can be foreseen is interfacing with the xcore.ai. The team must be mindful in choosing ports that are capable of sending and receiving data that the camera provides. In selecting the proper ports, the team needs to be mindful that it will not be infringing upon existing features for the XBOT. In addition, since our team is working off of an existing PCB, finding room for the required components associated with the camera may be difficult, and routing these components to the proper locations can prove challenging.

AI Creation: For the project to reach its ABO of a successful demonstration moving an object between two locations, the XBOT will need a reliable and efficient algorithm for object detection. The robotic arm will need to be able to differentiate between objects of different shapes, sizes, and colors, as well as determining the precise distance when lifting, positioning, and moving the object. Ensuring that the AI the team creates is both accurate and adaptive to a variety of objects and environments is a challenge we fully recognize, and it will require testing, fine-tuning, and validation to ensure consistent performance.

Motor Accuracy: This project is a continuation of a project from the previous year. Thus, much of the framework of the XBOT was created with that previous project in mind. It is possible that the previous team may not have chosen motors that are precise enough to perform the demonstration required for our project's ABO.

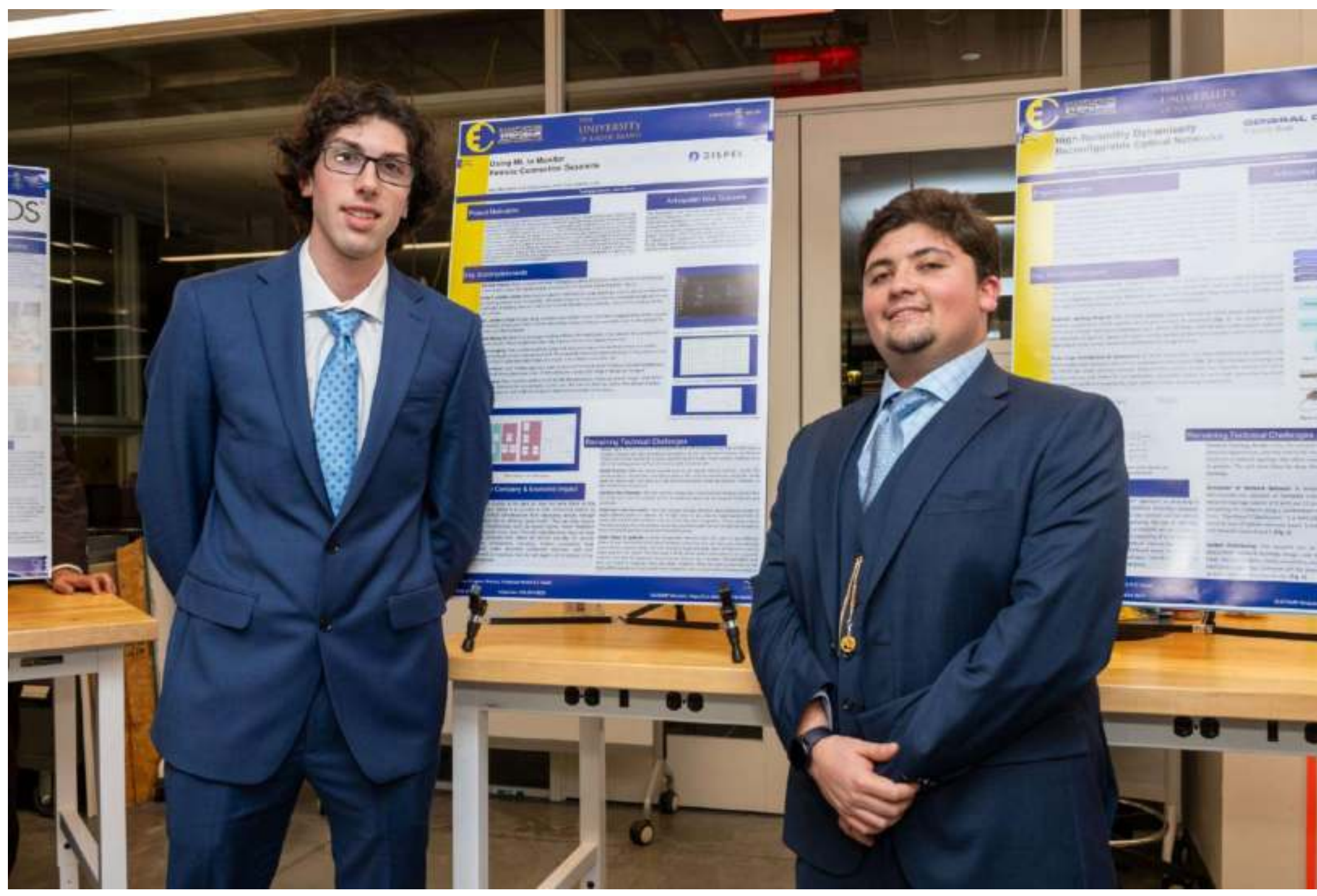

ELECOMP CAPSTONE SYMPOSIUM
THURSDAY, DECEMBER 19, 2024

THE UNIVERSITY OF RHODE ISLAND

THINK BIG WE DO™

Using ML to Monitor Remote Connection Sessions



Team Members: Noah Samuel Markus (CPE), Tyler Distefano (CPE)

Technical Director: Dean Macris

Project Motivation

Dispel provides secure remote access for customers to various critical infrastructure networks. The Dispel Zero Trust Engine for Remote Access (DZTE-RA) instantiates a composable workstation (Virtual Desktop) for engineers to maintain or service programmable logic controllers (PLCs) or access other engineering workstations inside the environment. The DZTE-RA provides a feature of screen recording that enables an administrator to review or even watch the actions any engineer is accomplishing in the environment. For larger systems, administrators can't watch or even review all screen recordings unless there is some event that triggers review (an incident or mistake was made). Dispel is interested in designing a system that can categorize different types of user actions through screen recordings. These actions are classified based on administrator-designed rules. The end goal is to enable an anomaly in the engineer's action (using the wrong program or running unauthorized commands) to trigger an alert and disconnect the system from the network.

Anticipated Best Outcome

The Anticipated best outcome for this project includes developing models to categorize 50% of customer applications. In addition, the team will also develop a method for training additional applications, designed into the platform. In order to train the AI and allow it to detect anomalies we need to create the ability to pull text commands from the screen recordings. If the timeline allows, Dispel would like to integrate an aspect of the project into the current DZTE-RA software stack. Finally Dispel would like to give its capstone students some real life experience by integrating them into the dispel engineering team.

Key Accomplishments

Dataset creator: Noah created a dataset initialization python script that takes a list input variable and then creates a new CSV based dataset and uses the list input to create features. (Fig. 2)

Feature addition script: Next Noah created an add features script allowing a user to add new features to an existing dataset via a list variable. The script checks to make sure that the new features added are not duplicates of existing features, and it also ensures that during this process, none of the existing data is overwritten.

Data addition Script: Finally, Noah created a data addition script that takes scraped text and then counts the number of features it finds. It then takes these counts of features and adds them to the dataset for future use in the AI model.

Model Research: Noah has also begun testing different AI models with a test dataset he created with the dataset creator. These models include K-NN, Random forest, and logistic regression.

Screen Scraping: Tyler created a python script that captures images of a desktop screen at a certain interval while the screen is being recorded. This is possibly the most important step of this project as it is the first step in collecting data to train the model and or detect anomalies live.

Image analysis: Tyler created a python script to take the five most recent of these captured images and check the difference between them. It then produces a gray scale image of what has changed.

Text scraping: Tyler created a python script to take the previously created grayscale image, read all the text from it and store this in a string for further use. This data can then be used by the dataset creator, feature addition, or data addition scripts to help train the model in the future.

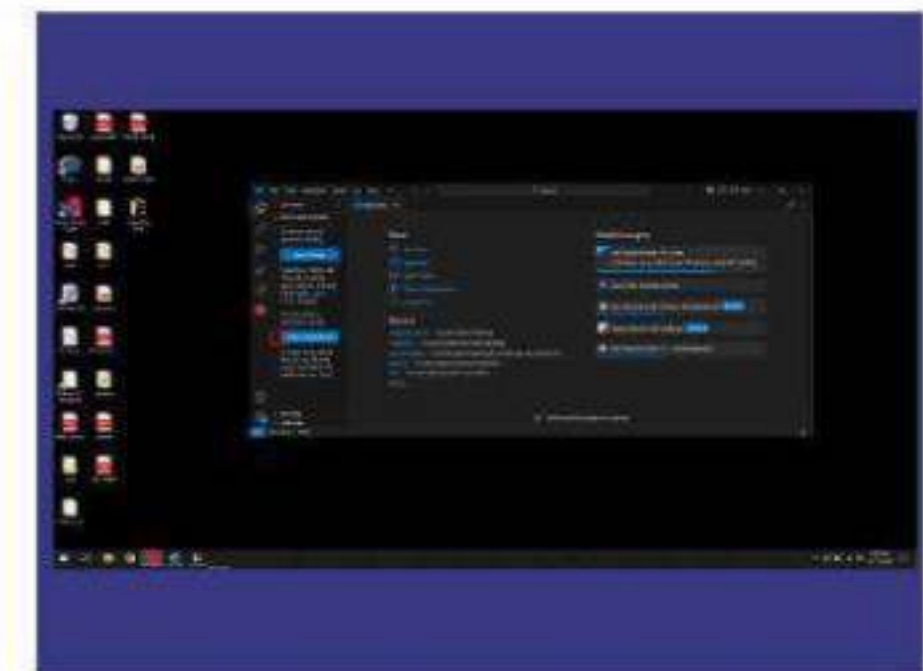

A screenshot of the results from the current icon match

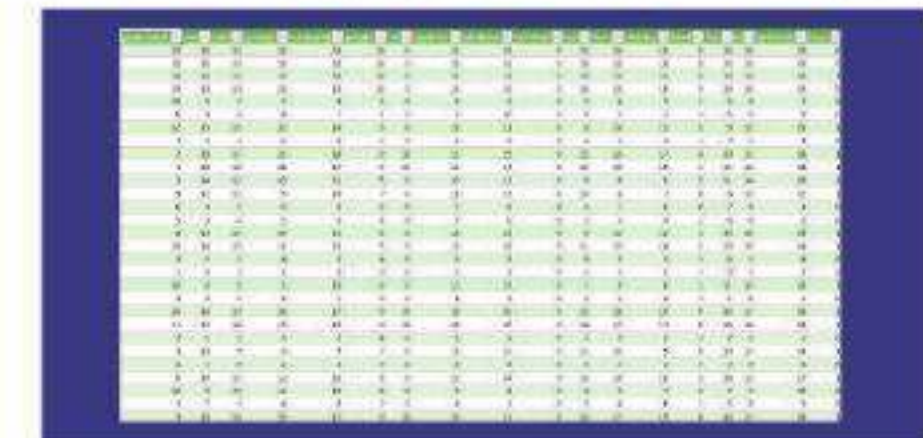

Test classification dataset used for model research

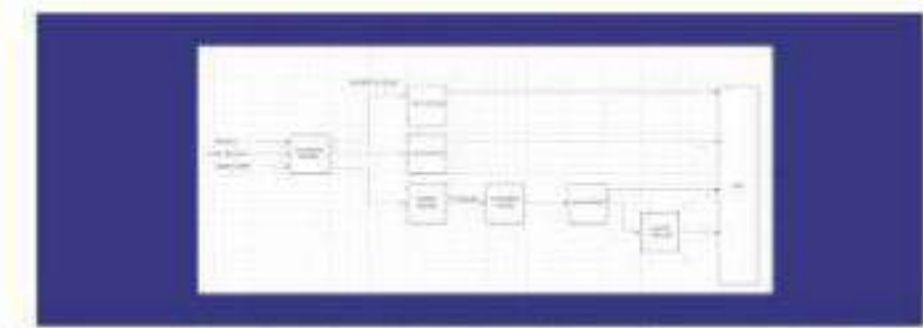

A diagram of how the data collection scripts will be combined together

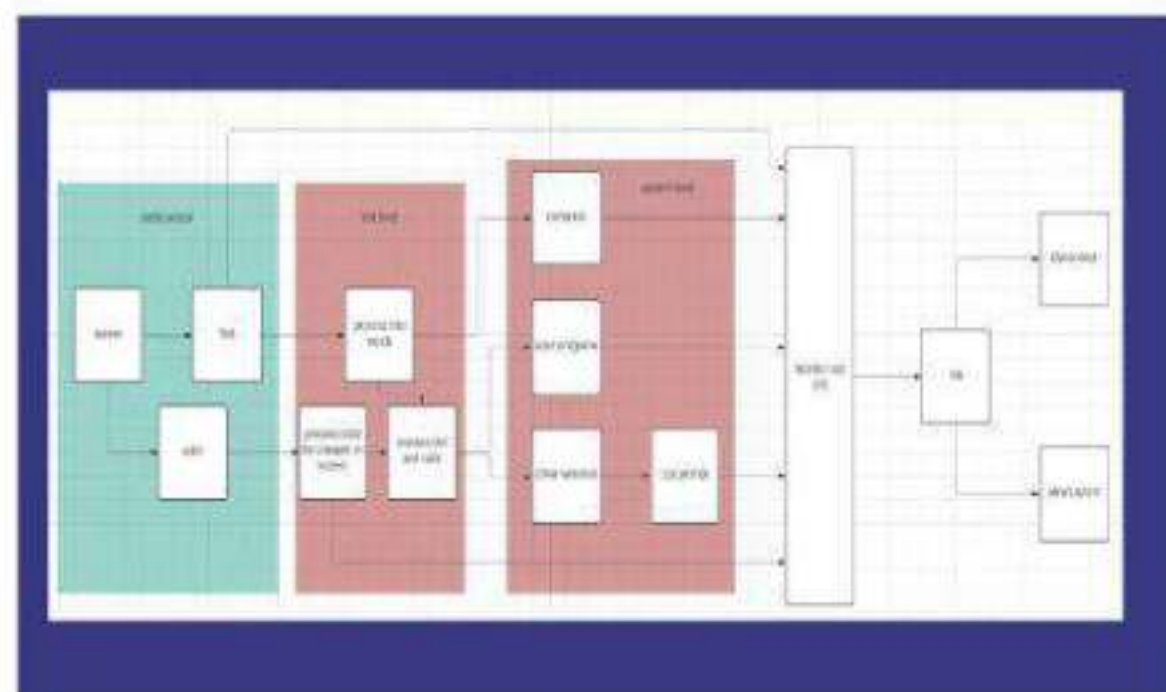

Block Diagram of initial design

Remaining Technical Challenges

Model Type: The first technical challenge that Noah will be facing is selecting a model type to properly analyze the data and detect anomalies. So far he has been testing classification models with a test dataset he created using the dataset scripts I have created. However, he is still in the testing phase and has not come up with a decision yet.

Model Training: After we choose a model type to use, we will need to develop a model that can be easily re-trained when new data is added. This could be achieved by saving the model and then adding new train data to it and then retraining the model periodically. However, at the moment we are not sure.

Live Real time Detection: We will need to incorporate a live-streamed desktop session that can at the same time be watched by the AI model and then end the session if it detects any anomalies.

Finish data collection scripts: Tyler has created multiple different data collection scripts to target different points of interest. As of right now he has ones to target general text on screen, the current open window, and one that does icon recognition. These scripts need a little fine tuning as they still produce some false positives with the icon recognition as well as some of the words getting skewed with the text capture.

Collect videos to generate: In order to generate datasets Tyler will need to feed different videos of user interactions to his data collection script first this will then give the collected data to Noah's dataset builder. We will require at least two main types of videos in order to create and test our model. The two types include videos where users actions are purposely malicious and then the opposite normal actions that are not malicious. This will allow us to train our model to recognize these two types of actions. Once we have a clear line on the binary difference we can start to add other categories with varying levels of malicious actions.

Implications for Company & Economic Impact

Dispel is hoping to be able to take the work done in this project and utilize it to provide a first-of-its-kind system to protect critical infrastructure from obscuring activity through the Dispel tool by utilizing "jump hosts". This can help secure critical infrastructure such as power plants, water treatment facilities and much more. This will help Dispel as they can now offer a program that offers all around security for remote desktop connections including, limited connection time windows, video recorded connection sessions, and now monitored connections that do not require an employee to be watching live.

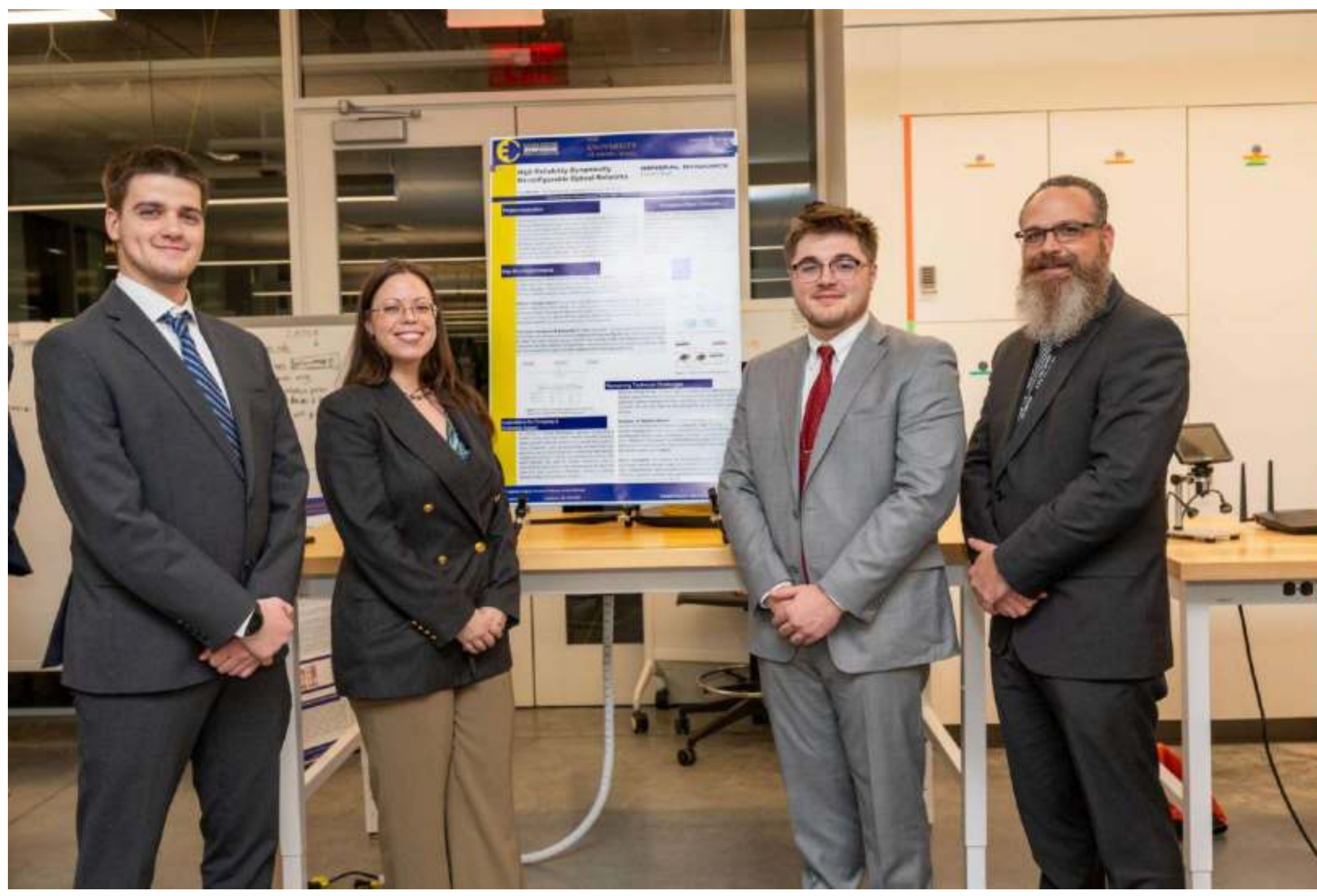

ELECOMP CAPSTONE SYMPOSIUM
THURSDAY, DECEMBER 19, 2024

THE UNIVERSITY OF RHODE ISLAND

THINK BIG WE DO

High Reliability Dynamically Reconfigurable Optical Networks

GENERAL DYNAMICS
Electric Boat

Team Members: Kylie Pasternak (ELE), Austin Noon (CPE), Alexander Gill (ELE)

Technical Directors: Michael Brawner, Joshua Malero | **Consulting Technical Director:** Mike Smith

Project Motivation

The motivation behind this project is to find a way to incorporate next generation add-drop networking technology into a fiber optic network. The goal is to investigate and assess technology options, develop simulation models, and prototype an on-demand, dynamically reconfigurable network that can enable highly reliable system flexibility. By successfully doing so, capstone designers will enable a new approach to providing a flexible, robust, and highly reliable interface boundary between system providers and the ship networks, known as "Tactical Middleware". Achieving this would reduce platform integration costs and improve the integration of next generation networking systems into current networking infrastructures.

Anticipated Best Outcome

The best outcome will be achieved when capstone designers gain hands-on engineering experience in the areas of:

- System design
- Technology investigation and assessment
- Simulation modeling
- Prototype fabrication
- Software development

Capstone designers are expected to successfully design, simulate, and prototype a dynamically reconfigurable network.

Key Accomplishments

Extensive Background Research: Capstone designers have researched a broad range of fundamental concepts and technologies applicable to this project. Topics include basic routing, types of networks and network topologies, multiplexing methods, fiber, types of optical-add drop multiplexing (OADMs) and their use in optical networks, media converters, and network simulation.

Notional Topology Diagram: The Notional Topology Diagram depicts our initial design configuration of network components which satisfies the project concept of operations (Fig. 1). The project requires three total subnets, five channels between each subnet, 10 nodes, and two spare nodes (spare nodes are not depicted in Figure 1). Signals will come into the system at the microcontroller, which will route each input signal based on our Command and Control (C2) programming.

Technology Investigation & Assessment: A "trade space area" has been defined which identifies the technologies and hardware that will be investigated and assessed (Fig. 3). Pugh matrices are being used to inform the down selection process because they provide a clear and objective answer to which components are best suited for our application. Evaluation criteria for each trade space area has been defined and significant progress has been made to finalize technology assessments.

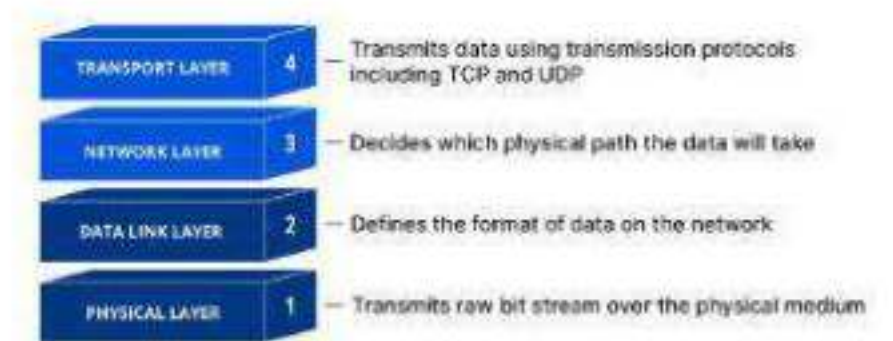

Figure 2: Layers 1-4 of the seven layer OSI Model.

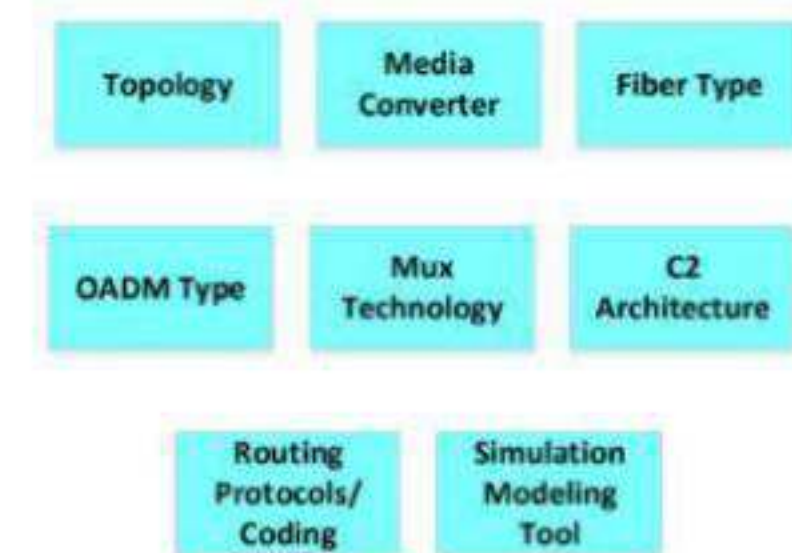

Figure 3: The identified trade space areas.

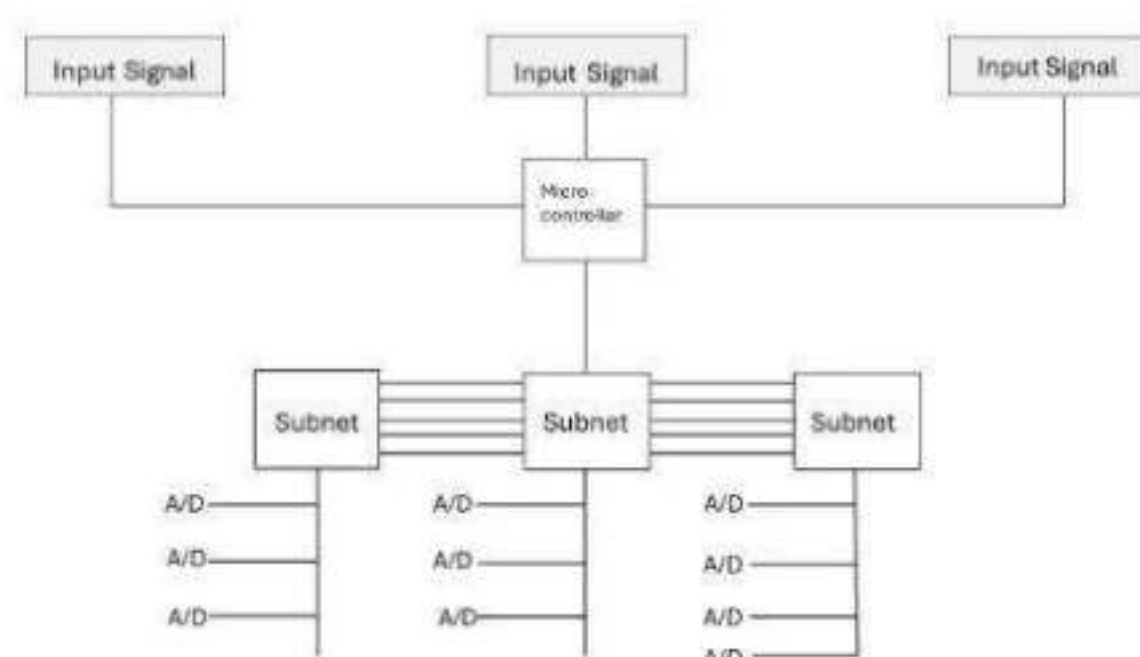

Figure 1: A Notional Topology Diagram which depicts our initial design configuration of network components.

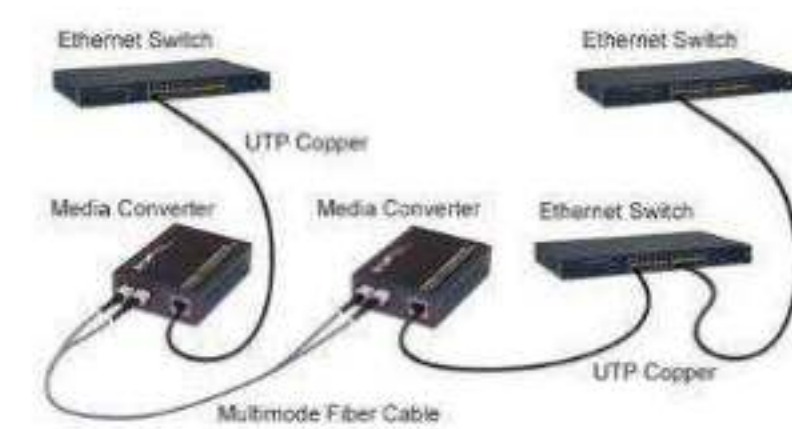

Figure 4: Copper-to-Fiber network hardware.

Remaining Technical Challenges

Network Topology Design: Using the notional topology diagram (Fig. 1), the given network requirements, and the criteria for the pugh matrix, the team will need to construct a network topology that offers redundancy, reconfigurability, and built in growth. This will most likely be done through the use of a hybrid network topology.

Simulation of Network Behavior: A network simulation will be created to demonstrate the behavior of hardware components (Layer 1) in our designed network topology (Layers 2/3) with our C2 programming (Layer 4). We anticipate simulating the network using a combination of available and supported software tools. "OptiWave"/"OptiSystem" is a MATLAB/Simulink plugin for simulating the physical layer of optical networks (Layer 1) and Cisco Packet Tracer can be used to test network Layers 2 and 3. (Fig. 2).

System Prototyping: The network can be prototyped when the technology assessment, network topology design, and simulation are successfully modeled. Fiber, microcontrollers, media converters, and optical add-drop multiplexers, and additional supportive hardware will be procured, assembled, programmed, and tested to confirm previous results. (Fig. 4).

Implications for Company & Economic Impact

By enabling a "Tactical Middleware" approach to providing a flexible, robust, and high-reliable interface boundary between system providers and ship networks, our sponsor will be able to reduce integrations costs. By incorporating the use of the next generation add-drop technology into a network, we would greatly increase the flexibility, reliability, and capability of a network. We would eliminate the need for manual intervention when a network device goes down, as the network would be able to fix itself. This poses significant advantages, including a positive economic impact, for our sponsor company.

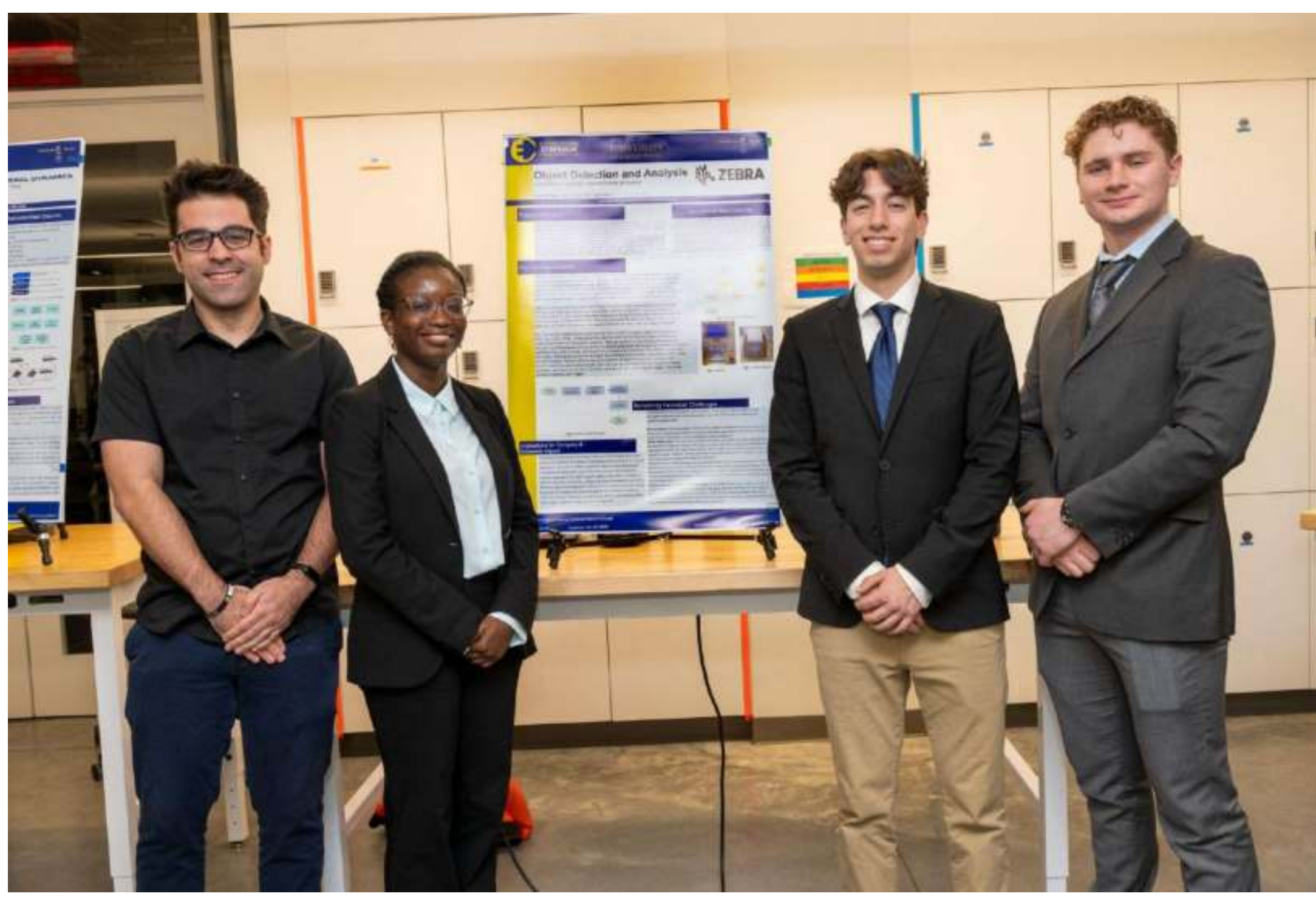

ELECOMP CAPSTONE SYMPOSIUM
THURSDAY, DECEMBER 19, 2024

THE UNIVERSITY OF RHODE ISLAND

THINK BIG WE DO™

Object Detection and Analysis

Using Machine Learning to improve thermal print quality



Team Members: James Furtado (CPE), Ryan Steele (CPE), Korali Kouadio (CPE)

Technical Directors: Matthew Corvese, Patrick Hegarty

Project Motivation

This project aims to optimize the accuracy of Zebra Technologies' thermal printers' outputs. Thermal printers are at risk to printouts that appear smudged, blurry, or misaligned. This affects the quality and legibility of printed materials like labels and receipts, which can pose issues for consumers of Zebra's products. These issues stem from the limitations of thermal printing technology.

By leveraging Machine Learning, the project seeks to develop an automated system to detect and correct these flaws in real time. This approach not only reduces the dependency on human intervention but also enhances the reliability and efficiency of Zebra's printing solutions. This solution has the potential to significantly improve customer satisfaction by delivering consistently high-quality printouts while allocating more company time toward other ventures. This innovation aligns with Zebra's commitment to advancing technology and maintaining its competitive edge in the industry.

Anticipated Best Outcome

The ABO of this project aims to deliver a Machine Learning model that enhances Zebra Technologies' commercial printer outputs (cf. Fig.1). The system begins by capturing an image of the initial printout. Then, the model searches for specific dot patterns. Once these patterns are found, they are analyzed and compared with their ideal versions. This allows the model to make adjustments needed to achieve the intended print. This process is iteratively repeated, reprinting until optimal print is achieved. The model also saves adjustments which will improve the output and quality of barcodes and text. A user-friendly interface will provide real-time tracking of progress and adjustments, ensuring optimal print quality with minimal user effort.

Key Accomplishments

Hardware Selection: The first step in our process is to capture the image (cf. Fig.1). To set up our physical working environment, we first needed to decide on a camera. After going through the potential technical requirements, especially when it came to the resolution and magnification capacities, we chose the TOMLOV DM9 Digital Microscope (Fig.2). Next, we have the ZQ620 Plus, our thermal printer provided by Zebra Technologies (Fig.3). It's a compact powerhouse for thermal printing of labels, receipts and barcodes that can be connected wirelessly or via USB.

Machine Learning (ML) Selection: After researching a few models we could use, we selected YOLOv5 (You Only Look Once) as our main object detection algorithm. It is a convolutional neural network or CNN-based model that is known for being fast, accurate, and easy to use. The main advantage of CNN models is that they can automatically learn and extract from raw pixel data. So, the model can discover and adapt to features we need, such as shapes, colors, etc.

ML Training: Our model follows a basic pattern as it is still in the early stages of development. First, we create a YAML configuration file, which is essential for YOLO to locate the data and understand it before it can predict anything. Then, we move on to the training function which uses the specified dataset and parameters. It takes 3 arguments: the image size, number of epochs and batch size. After training, the model is then tested with a function using inference and saves the results. This function takes the test path and confidence threshold as arguments. Lastly, inside the test function, the core inference process happens through the detection function. This function loads the best trained weights from the training, processes the test images for object detection, and saves the results in text files, confidence scores and cropped images. This entire process is summarized in Fig.4.

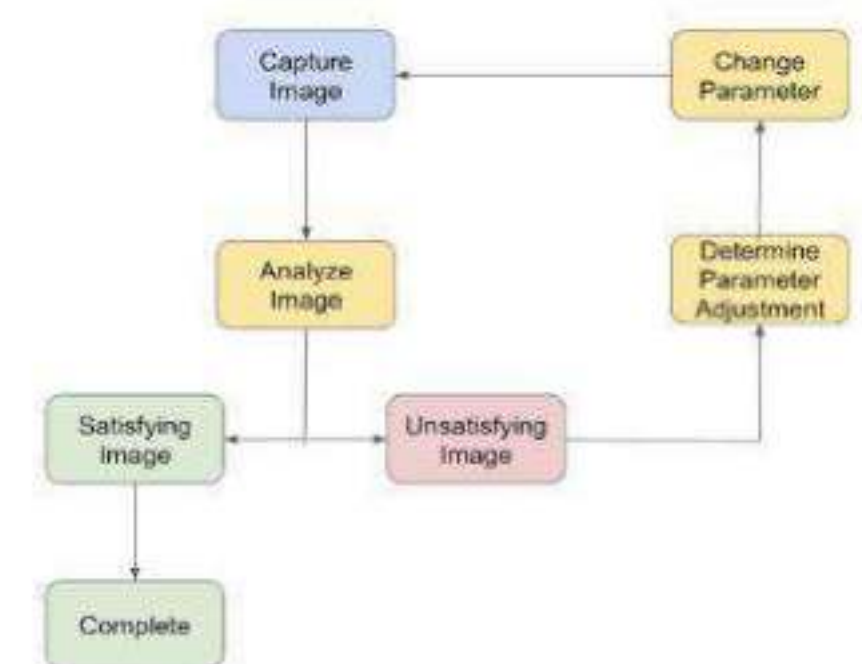

Fig.1: Project's Block Diagram



Fig.2: Camera



Fig.3: Printer ZQ620+

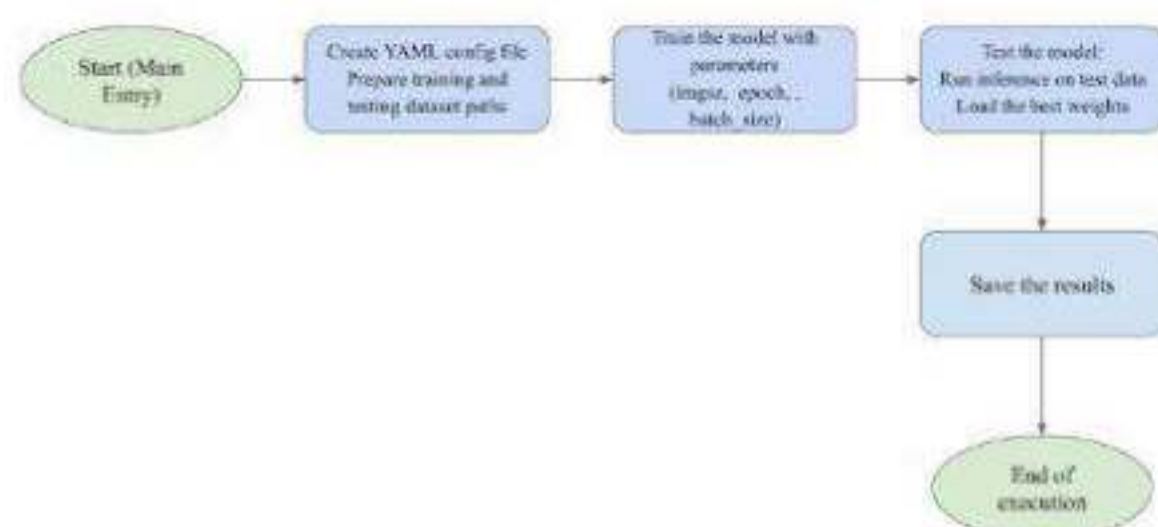

Fig.4: Current Model Flowchart

Remaining Technical Challenges

Our current model is quite straightforward and generic. For our team to reach our ABO, we must still improve our model with various functionalities, especially when it comes to evaluating and grading the data provided.

Dataset Quality: Our training dataset will have to be expanded to increase the accuracy and help our model learn more to adapt better and faster. So, we need to focus data augmentation as our next step. We must also ensure the data is balanced to avoid oversampling or undersampling issues.

Model Enhancement: We could better hyperparameter tuning. For example, we could experiment more with the batch size or image size. Increasing the image size might require more computation and memory, while a larger batch size would also require more memory. Thus, we might have to consider working with a more powerful computer. Therefore, we must experiment to find the best trade-off. We could also try and implement batch normalization to analyze the model more effectively.

Model Evaluation and Monitoring: We could use other metrics such as precision, recall, or F1 score and monitor the results over different dataset subsets to get a deeper insight in the model performance. We could also introduce confusion matrices to evaluate how well the model is identifying the classes and check whether it is prone to misclassifying some objects. We could also introduce some more tools to visualize the workflow while training occurs.

Model Complexity vs. Computational Resources: As our model becomes more complex, we will have to decide between speed and accuracy at some point. Once again, hardware capabilities will be crucial (e.g. GPUs). Or we could also consider processes such as model pruning (removing parameters that end up unimportant to reduce the model size) or quantization (a technique to reduce the computational and memory costs) to reduce the model size without affecting the performance.

Implications for Company & Economic Impact

Integrating AI and Machine Learning to improve Zebra Technologies' print quality will streamline development, reducing costs and time spent on manual adjustments. Automation will free engineers to focus on new projects and innovations, allowing Zebra to prioritize advancements while enhancing customer experiences. By improving print quality, this initiative strengthens Zebra Technologies' position as a leader in the direct thermal printing industry. Moreover, it lays the foundation for future AI-driven innovations, marking the beginning of a broader shift toward automation and intelligent technology within the company. This project could become pivotal in maintaining Zebra Technologies' competitive edge and advancing growth.

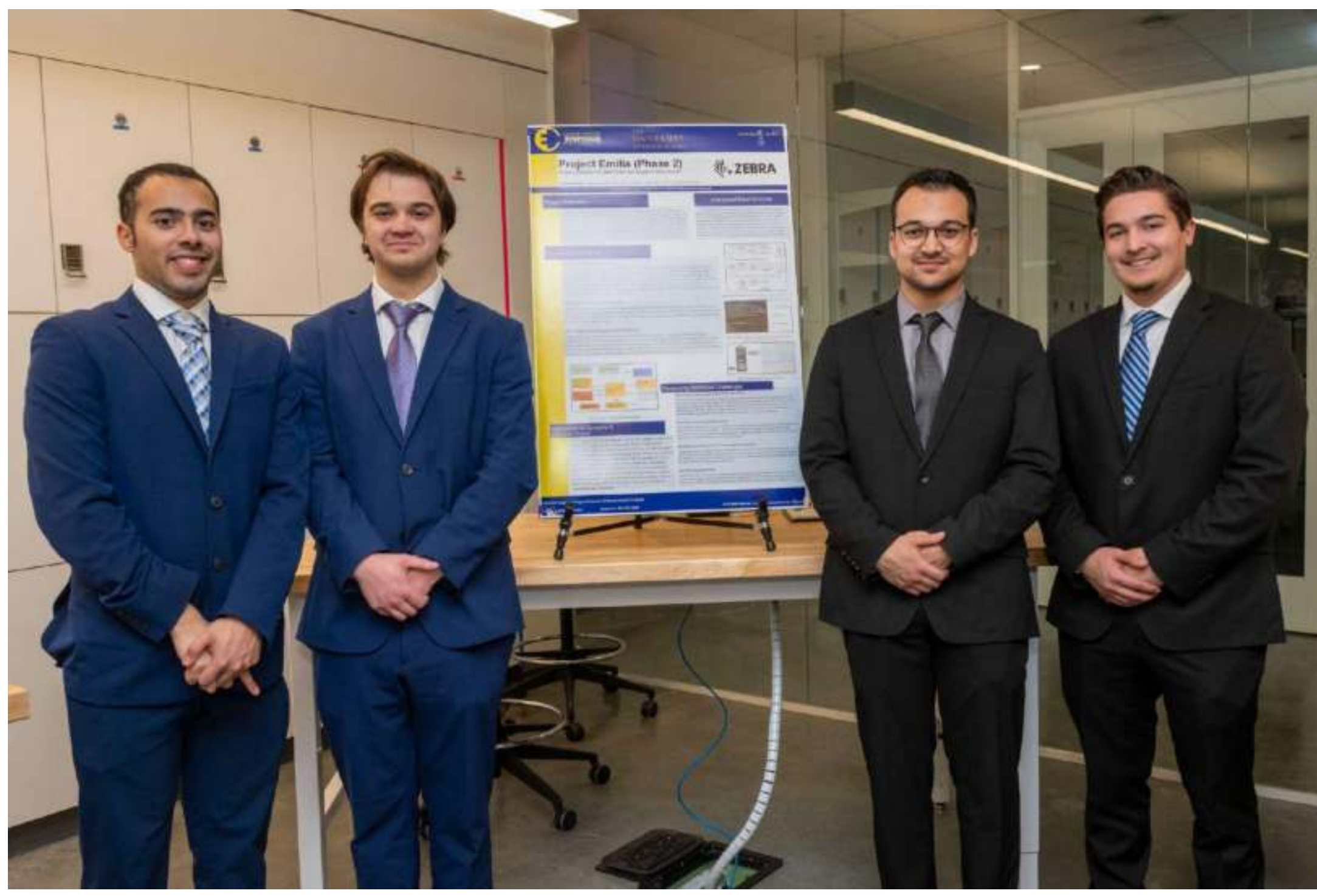

Project Emilia (Phase 2)

Wireless Enablement of Green Power Technologies for Edge Devices



Team Members: Ruben Germosen (CPE), Alex Lupo (CPE), Jake Nicynski (CPE), Joseph Kulik (ELE)

Technical Director(s): Joseph Moreira, Bradley Willard, Chris Rothwell

Project Motivation

In pursuit of Zebra Technologies' social and environmental goals, this project aims to improve the power efficiency and reduce both the carbon footprint and consumer costs of Zebra's products. Our team is motivated by the opportunity to make a meaningful impact on the world, benefiting both current and future generations. It's extremely important that we aim to reduce carbon emissions due to their harmful effects on the environment and public health, and we are very grateful to have the opportunity to help make a positive contribution towards the global efforts in achieving Net Zero by 2050. Our team is very grateful to be able to collaborate with Zebra Technologies on this innovative project and exciting opportunity as this project has the potential to positively impact millions of devices around the world reducing both carbon footprints and consumer total cost of ownership.

Anticipated Best Outcome

The anticipated best outcome of Project Emilia is to implement its green power charger with dual WiFi/Bluetooth architecture at the test fixture and pre-EVT levels. This hardware and software implementation will detect optimal charging times for edge devices, reducing both the carbon emissions and charging costs for Zebra Technologies' customers. Project Emilia will also use Google Cloud Run to store data captured by the microcontroller to allow users to visualize the reduced carbon footprint and cost savings via an app or website, showcasing the benefits of charging during peak energy outputs from the grid.

Key Accomplishments

MQTT Connection Broker Setup:

The MQTT connection is a messaging protocol that allows devices to use a publish and subscribe method to transfer data. Through this protocol, devices must subscribe or publish to topics that are inside the MQTT connection (Fig. 1). These topics contain the data published to the MQTT connection, which can be accessed by subscribing from other devices. The MQTT Broker is what the devices have to connect to in order to communicate with each other. The MQTT Broker that we used is created through Mosquitto, which is an open source MQTT protocol. After Mosquitto is downloaded, the MQTT connection can be started from a terminal on our device and other outside devices can connect and start publishing and subscribing to topics (Fig. 2).

ESP32 as MQTT Publisher and Subscriber:

Using the ESP32 microcontroller we were able to establish a stable connection to the MQTT broker over Wi-Fi. In the code, the topics for both subscribing and publishing were correctly configured within the MQTT broker setting, allowing for communication between the ESP32 and broker. This entire setup required only two libraries: one for handling MQTT communication and another for Wifi.

ESP32 Voltage Wakeup Signals for Existing Hardware:

Using an MQTT broker to send and receive data with the ESP32 over Wi-Fi, we were able to have the broker communicate with the ESP32 microcontroller to turn on and off voltage signals based on the data the ESP32 received. These signals act as on and off commands for the existing hardware. To match the need of the existing hardware, we dedicated three pins on the ESP32 for wake up signals (Fig. 3), one to power on Zebra Technologies' existing hardware microprocessor, the second to enable charging, and the third to activate the printer (Fig. 4).

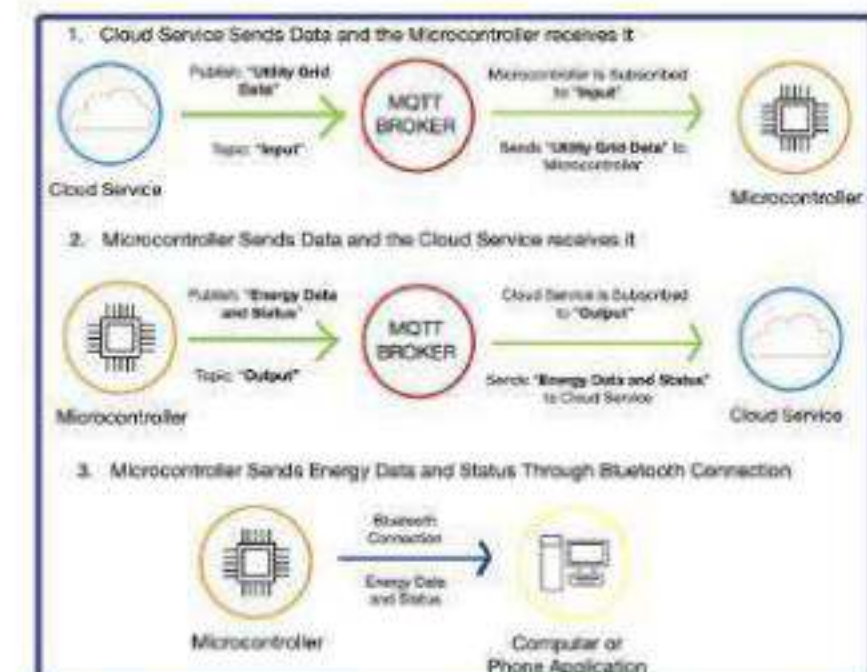

Fig. 1: MQTT Broker to the Cloud Service, Microcontroller, and Bluetooth App

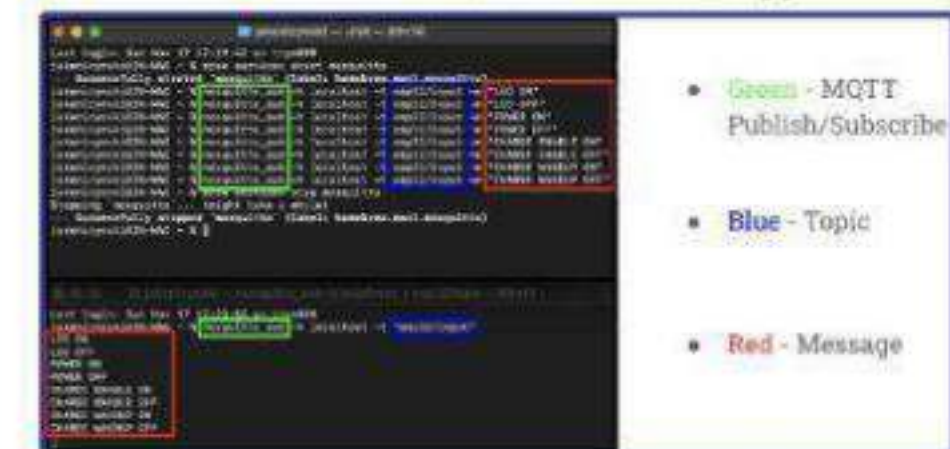

Fig. 2: MQTT Broker both publishing (Top Terminal) and subscribing (Bottom Terminal)

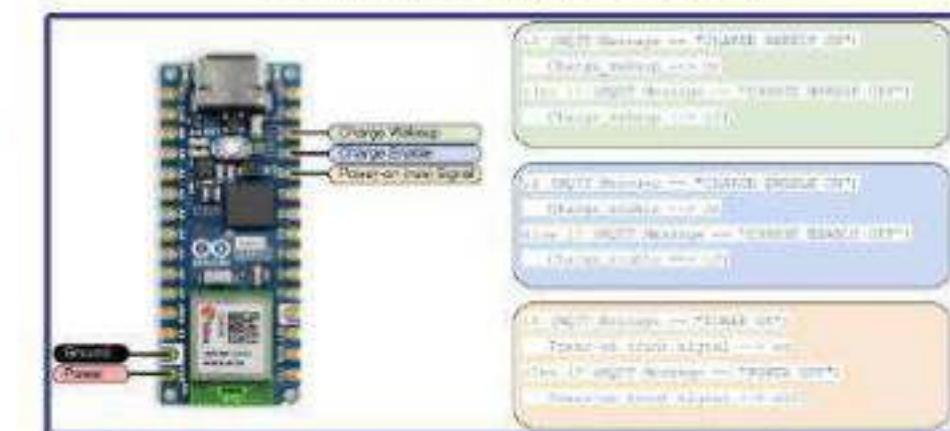

Fig. 3: Arduino Nano Esp32 Pin Diagram

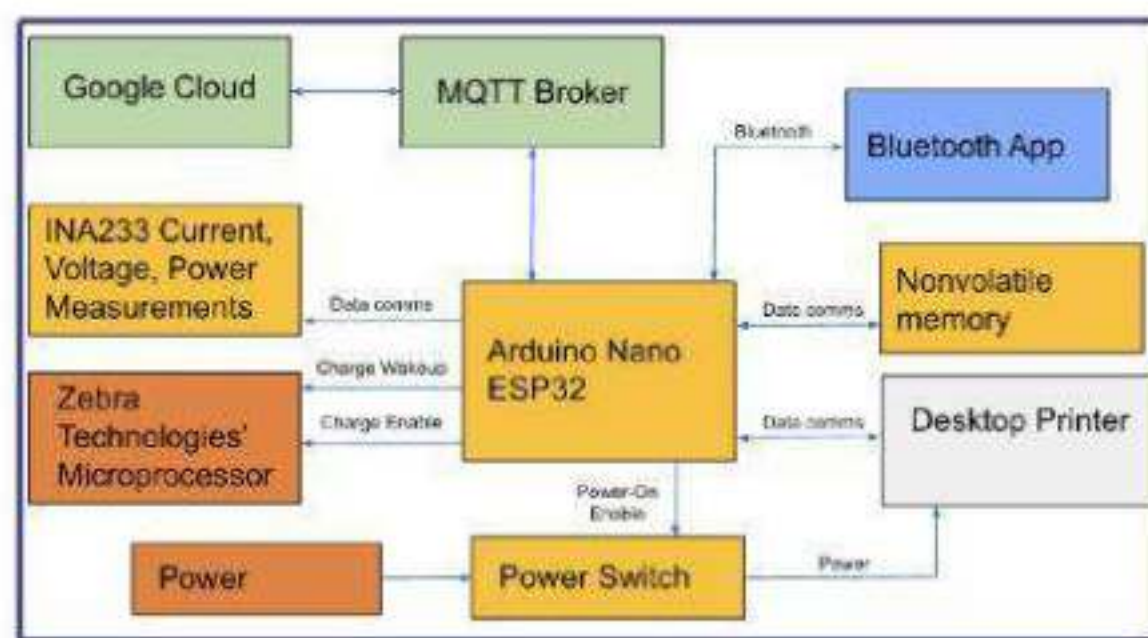

Fig. 4: Arduino Nano ESP32 Block Diagram

Remaining Technical Challenges

Bluetooth app/website to connect to the Arduino Nano ESP32:

The bluetooth app/website will be able to display real time data and cumulative energy consumption data in watt-hours, as well as show the current status of the charger hardware. From the app the user will also have the ability to manually override the green energy software to charge the printer if needed. Some of the challenges will be implementing the bluetooth connection with the existing Wi-Fi/MQTT communication code. Additionally it is important that the app maintains a user friendly interface that the user can understand and manage.

Using Google Cloud Run as cloud service tool:

The cloud service tool that we are using for this project is Google Cloud Run which allows us to take in Utility Grid data to use for the MQTT Broker (Fig. 1). This cloud service will also keep track of the power packs energy consumption and will get that data from the Arduino board. Additionally Google Cloud Run will be used to build a carbon metric dashboard which shows the CO2 emissions data.

Interpreting data from WattTime to determine optimal charging time:

An important aspect to our project's success is the ability to determine the optimal charging time. To do so we will use WattTime which is a nonprofit organization which provides information about the local utility grids. Working with WattTime, we will be able to read in data for the user's local utility grid and determine the optimal charging time based on the user's utility grid and usage patterns.

INA233EVM Evaluation Board:

The INA233EVM Eval board works as both a current shunt and a power signal monitor, which can be used to monitor various signals across the existing hardware. Using the INA233EVM we can provide information to the Arduino Nano ESP32 microcontroller on the real-time and cumulative energy consumption used (Fig 4).

Implications for Company & Economic Impact

In support of the United Nations' call for all countries to reach Net Zero by 2050, successfully implementing Project Emilia would significantly reduce the carbon footprint of millions of Zebra products per year while also reducing the electricity usage paid for by customers to power Zebra's products. Additionally with the addition of Project Emilia, both product differentiation from competitors, and market share would be expected to increase as more and more prospective buyers are prioritizing TCO and emissions in their decision-making processes. By addressing both environmental and economic concerns, Project Emilia helps Zebra Technologies stand out as a leader in sustainability and innovation.



ELECOMP CAPSTONE SYMPOSIUM
THURSDAY, DECEMBER 19, 2024

THE UNIVERSITY OF RHODE ISLAND

THINK BIG WE DO™

Safety Critical Applications for RISC-V Platforms



Team Members: Jeshua Benzant (CPE), Adam Lubinsky (CPE), Nathan Kaye (ELE)

Technical Director(s): Steve Lawrence, Mike Smith

Project Motivation

The race for space is real and happening now, and Draper is on a mission to lead. Safety critical applications and computer platforms are a part of Draper's DNA that go back to the Apollo era guidance computer. Developing the next generation of this technology is critical to our national defense. We are looking for a motivated student team to support development of a safety critical application using the Rust programming language on a RISC-V platform.

Anticipated Best Outcome

The goal is to create a Rust application on a RISC-V platform and identify security features of Rust used to increase robustness of the application.

1. Detailed system level design document including system ICD
2. Detailed hardware design of system & Detailed software design document
3. Software test plan & Integration test plan
4. Source code
5. Compiled binaries
6. A working prototype system
7. Technology assessment report including
 - a. Security assessment of Rust
 - b. Benchmark of RISC-V architecture performance
 - c. Benchmark of GPU performance

Key Accomplishments

Key Features and Their Relation to the Project

1. **PID Control System:** Enables precise ball control by dynamically adjusting rail angles based on real-time feedback, ensuring consistent performance in the 'Shoot to the Moon' game.
2. **Camera and LIDAR Integration:** Provides accurate position and velocity tracking of the ball, critical for feedback in the control loop.
3. **Servo Control Mechanisms:** Drives the dynamic movement of the rails, directly affecting the trajectory and outcome of the game.
4. **Real-Time Programming in Rust:** Ensures reliable and efficient system performance, demonstrating the feasibility of Rust in safety-critical applications.
5. **Hardware-Software Integration:** Seamlessly combines sensors, actuators, and processors, forming the backbone of the system.

Breakdown of Block Diagram

The system consists of a **camera** for ball tracking and **LIDAR** for velocity and position measurements. Data is sent to the **GPU** (for image processing) and **CPU** (for executing control algorithms). The **actuators**, controlled by the CPU, adjust the rail angles to influence the ball's motion. This closed-loop feedback system dynamically optimizes ball control based on real-time data.

Development Timeline

- **Phase 1:** Conduct research on control strategies, sensor placement, and system parameters. Validate control equations via MATLAB simulations.
- **Phase 2:** Select servo motors, LIDAR, design mounts, and create preliminary CAD models.
- **Phase 3:** Implement Rust programming, simulate PID control, and develop ball trajectory models.
- **Phase 4:** Integrate hardware with the BeagleBoard and begin testing servos and sensors.
- **Phase 5:** Optimize control algorithms and hardware-software integration. Conduct system-level testing.
- **Phase 6:** Finalize assembly, validate performance, and prepare documentation for submission.

This structured approach ensures cohesive development of a robust and efficient control system for the 'Shoot to the Moon' game, meeting both technical and project goals.

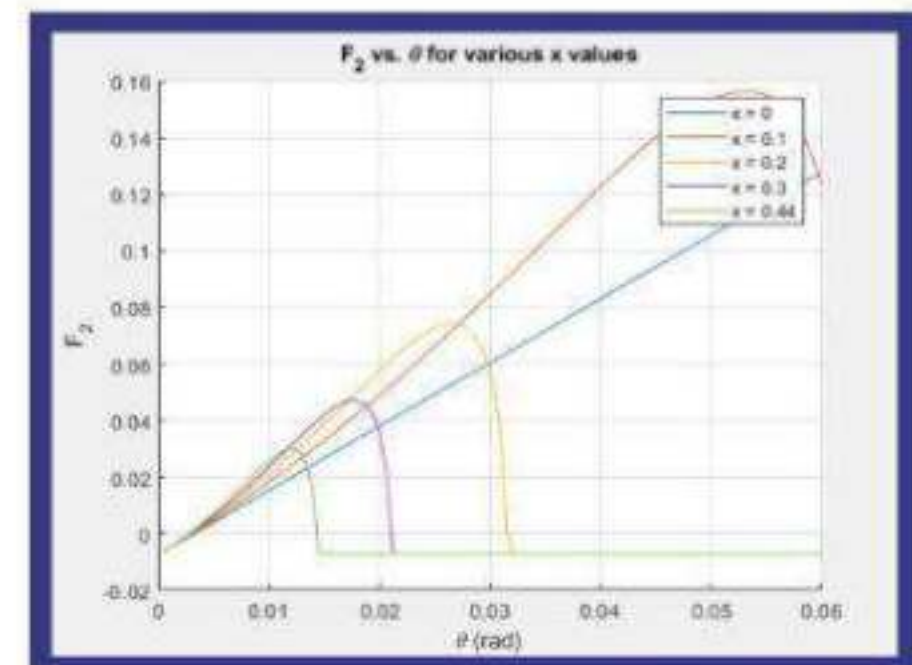

MATLAB from Control Theory

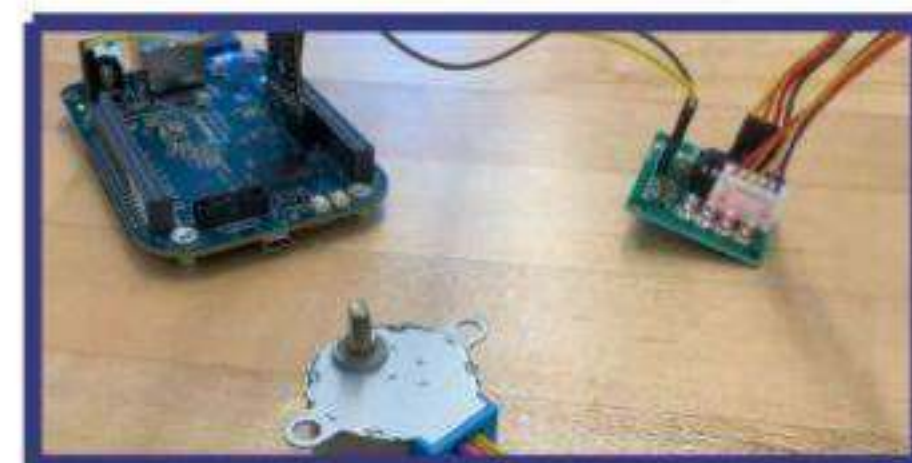

Beagle V Ahead Board with Current Motor

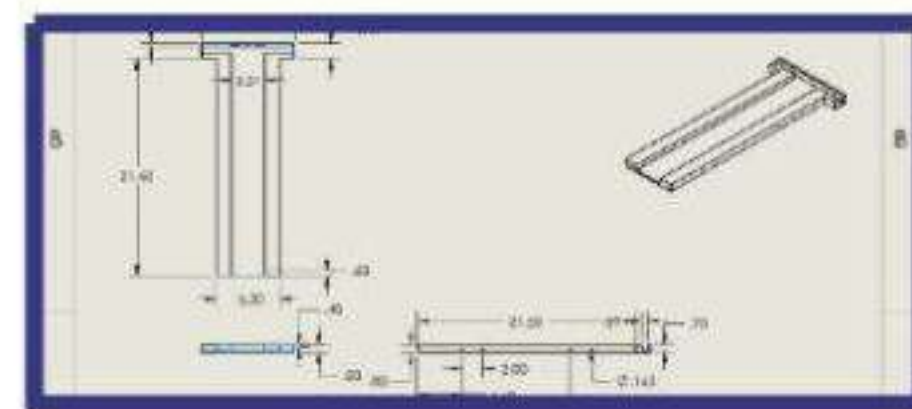

Sleeve for the "Shoot to the Moon Game"

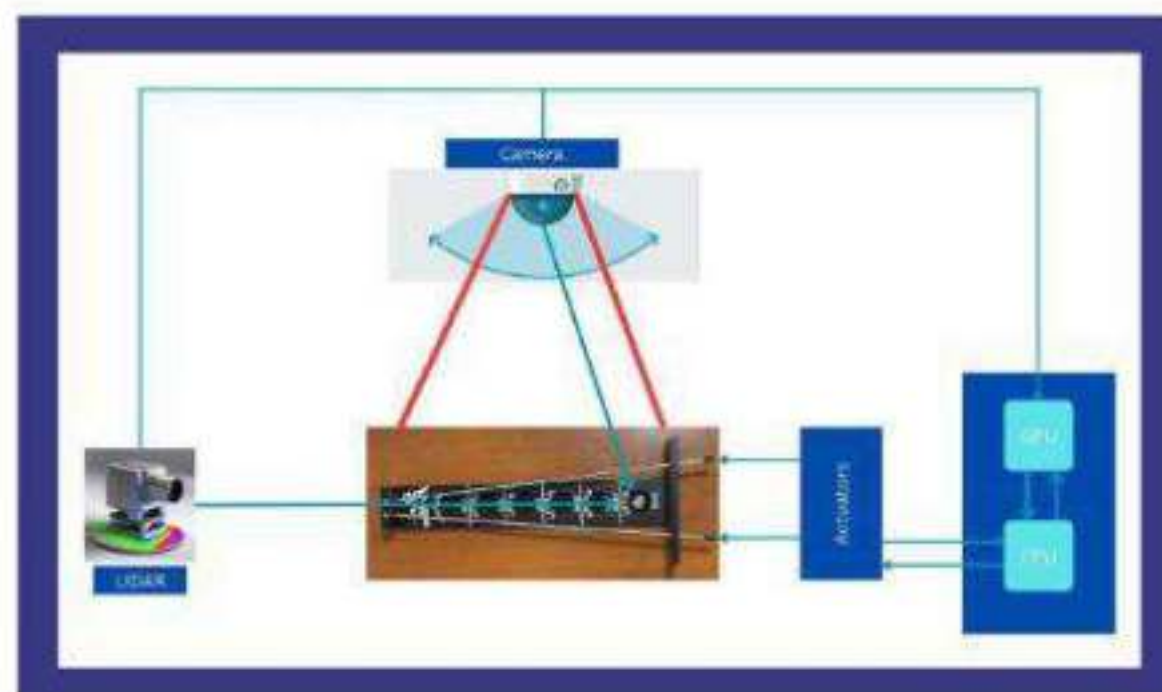

Block Diagram

Implications for Company & Economic Impact

Combining RISC-V and Rust for next-generation flight computers has transformative implications for Draper and the aerospace industry. RISC-V's open-source ISA reduces costs and fosters collaboration, while Rust ensures safety-critical robustness, essential for human space exploration. By leveraging these technologies, Draper positions itself as an industry pioneer, advancing space systems that are cost-effective and reliable. Globally, this project aligns with the increasing demand for open, secure, and scalable platforms, driving innovation and ensuring competitiveness in the emerging space race. Draper's commitment to these technologies not only strengthens its market presence but also shapes the future of aerospace engineering.

Remaining Technical Challenges

Key Design & Development

- Create detailed schematics and integrate hardware (LIDAR, camera, servos) with software.
- Leverage Rust for robust control equations and real-time performance.

Parts & Equipment

- Manufacture custom components and procure hardware, including LIDAR and actuators.
- Ensure compatibility, quality, and timely production for seamless integration.

Hardware & Software Integration

- Configure BeagleBoard, integrate sensors, and establish servo motor control.
- Implement Rust-based real-time control algorithms, OpenCL for image processing, and robust error handling.

Deliverables

- Produce system documentation, test plans, and validation criteria.
- Evaluate Rust and RISC-V platforms for safety-critical applications.

Performance Goals

- Achieve **80-100% success rate** in ball placement with stable operations.
- Deliver efficient motor control and reliable sensor data processing.

Challenges & Future Work

- Optimize servo response, sensor calibration, and Rust implementation.
- Scale the system for broader safety-critical applications.

This project combines advanced hardware and software to deliver a high-performance, safety-critical system leveraging RISC-V and Rust.

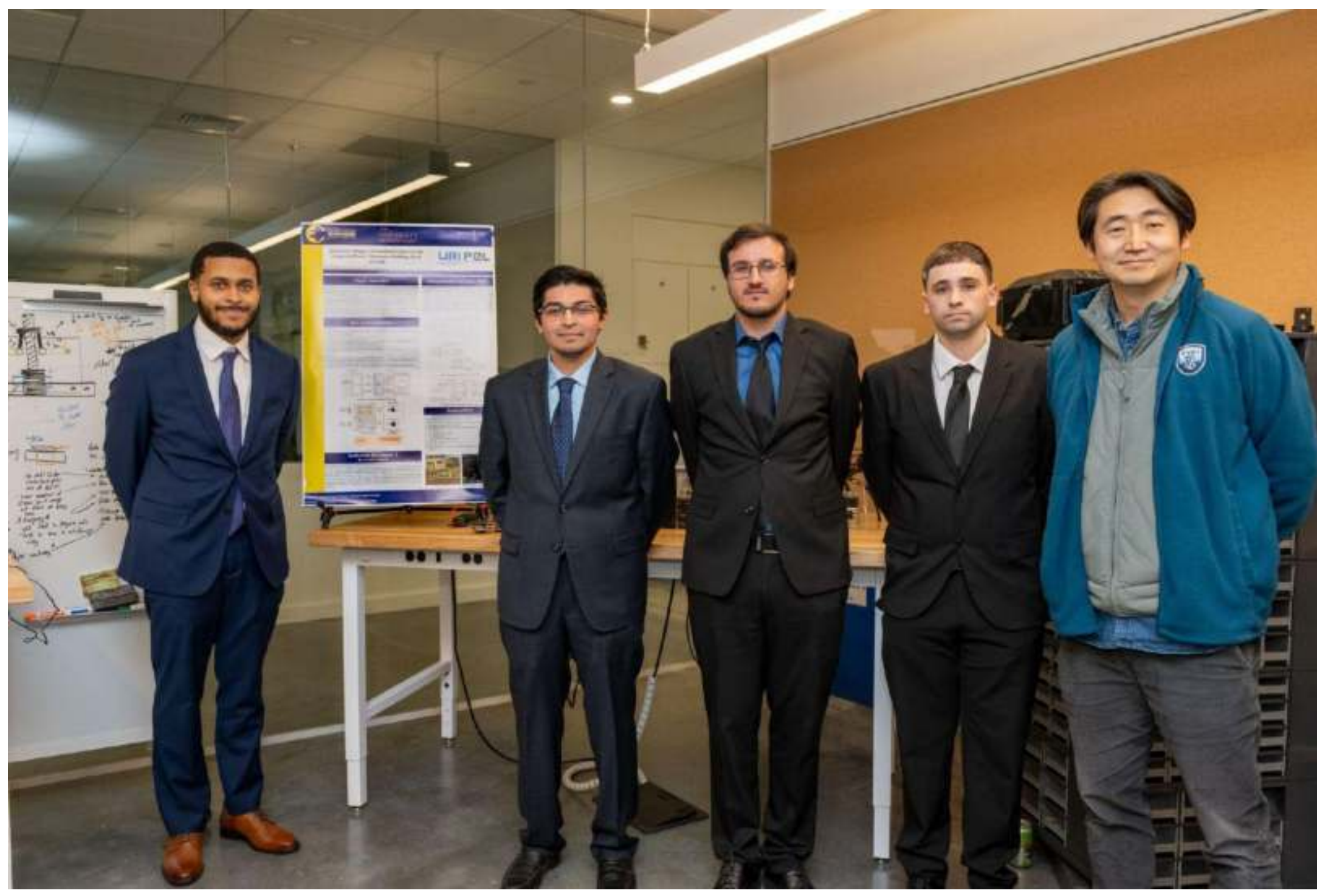

ELECOMP CAPSTONE SYMPOSIUM
THURSDAY, DECEMBER 19, 2024

THE UNIVERSITY OF RHODE ISLAND

THINK BIG WE DO™

Innovative Design Automation Framework for integrated Power Electronics Building Block (iPEBB)



Team Members: Max Bongiovanni (ELE), Patrick Feliz (ELE), Gianni Smith (ELE), Justin Smith (CPE)

Technical Director(s): Dr. Yeonho Jeong & Xueshen Zhang

Project Motivation

The design process is key to the performance of power conversion systems (PCSs). Traditional methods rely on human expertise, often labor-intensive and time-consuming, with varying outcomes and inconsistent results. PCS design must address unique targets and constraints for each application, from adjusting parameters to adopting new topologies, all aiming to improve efficiency, performance, and power density. Machine learning (ML) offers promising solutions, enabling precise and efficient parameter optimization. However, challenges remain, including the lack of standardization, numerous topology options, and complex design variables. This capstone project seeks to develop an innovative design automation framework for PCSs, leveraging modular power systems like integrated power electronics building blocks (iPEBB). The framework will incorporate ML-based tools, advanced methodologies, and heterogeneous computing to accelerate PCS design and manufacturing while drawing on power electronics fundamentals. This forward-thinking approach addresses industry needs by enhancing design precision and streamlining the overall development process.

Key Accomplishments

Hardware:

- Able to determine the appropriate load parameters for both the Hexacopter and Quadcopter, when given just their input source
- Decided upon an LLC resonant tank circuit topology
- Gathered research on LLC resonant converters
- Researched and designed an open loop control system designed for LLC resonant converters
- Created a circuit simulation using PLECS (Open Loop)
- Developed the Inverter Stage on a breakaway PCB (Printed Circuit Board)
- Built Drones and tested the Quadcopter and Hexacopters motors under Full-load

Software:

- Researched the preliminary AutoCkt and ML-Powelec code
- Researched Reinforcement Learning (RL) and how the Agent (algorithm given design constraints) would interact with the Environment (SPICE-Based Circuit Simulator)
- Implemented the Power Electronics Design Automation (PEDA) framework on a local FPGA

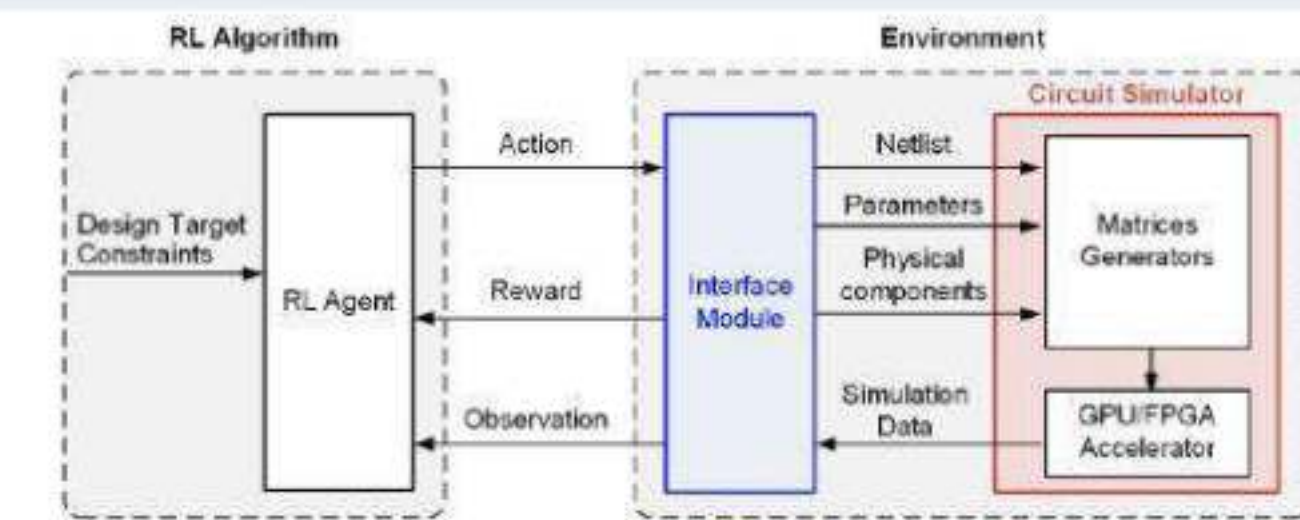

Architecture of the RL-based PEDA Tool

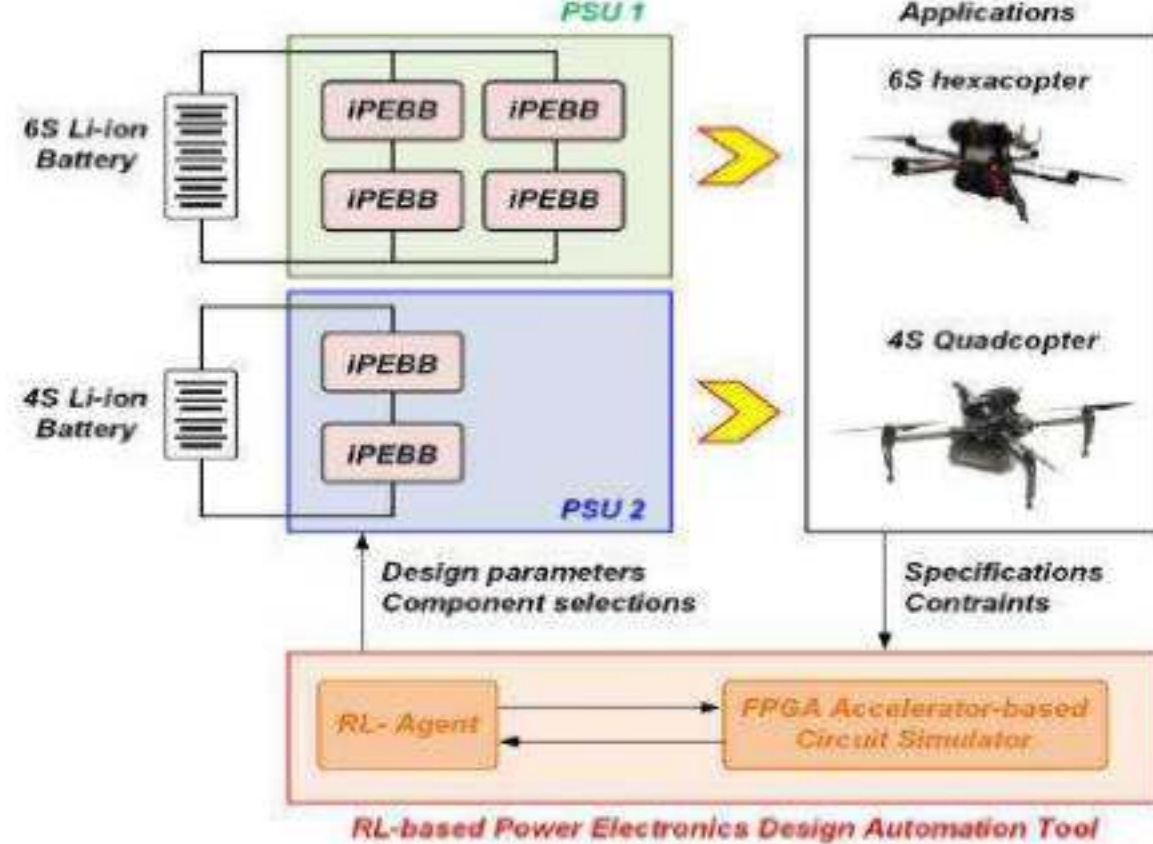

iPEBB Building Block

Implications for Company & Economic Impact

For a professor specializing in power electronics, this work provides a practical platform to validate theoretical models, contribute to cutting-edge developments in the field, and potentially open new avenues for further exploration. Additionally, the outcomes of this project could enhance the professor's research portfolio and lead to impactful publications or collaborations in academia and industry. In renewable energy, our work can improve the integration of cleaner power sources, making them more reliable and scalable. Furthermore, advancements in power electronics and converter technology could revolutionize modern systems used in electric vehicles, aerospace, telecommunications, and even healthcare. This project is a stepping stone toward innovations that will shape the future of energy and technology.

Anticipated Best Outcome (ABO)

The anticipated best outcome of this project, is a fully functional prototype of two power conversion systems for two different drone applications, 6-S hexacopter and 4-S quadcopter along with a power electronics design automation (PEDA) tool, implemented on heterogeneous computing using Amazon Web Services (AWS), OCT-FPGA, or others. First, based on the design outcomes from the PEDA tool and human effort, a single iPEBB will be designed, implemented, and evaluated to meet the electrical requirements, including a comparison of the two design outcomes. Subsequently, multiple iPEBBs will be configured and evaluated, and finally demonstrated by assembling them into two drones.

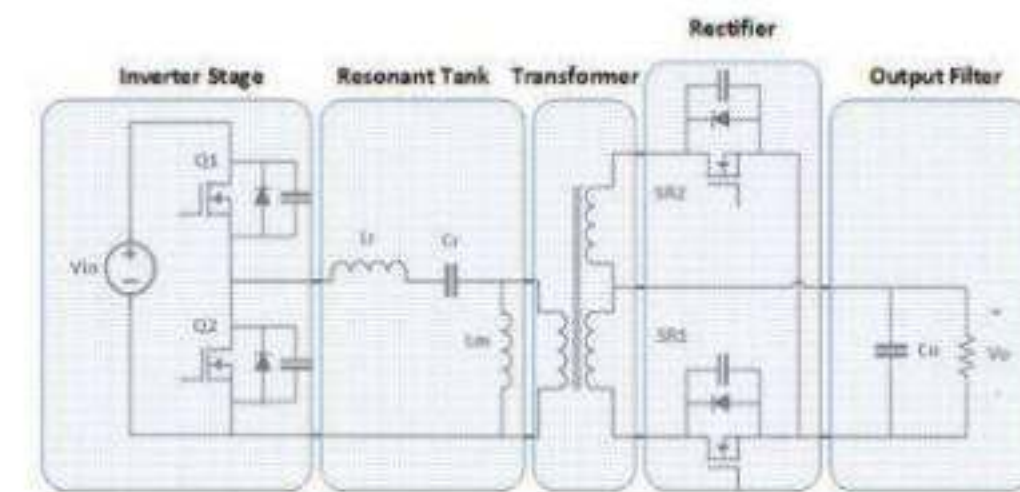

Half-Bridge LLC Resonant Converter

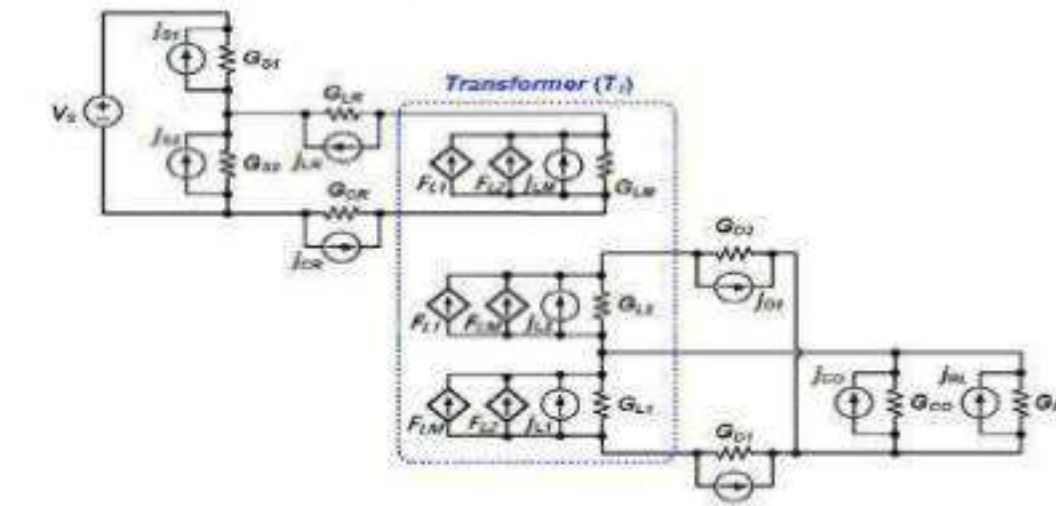

MNA Calculations of the LLC Converter

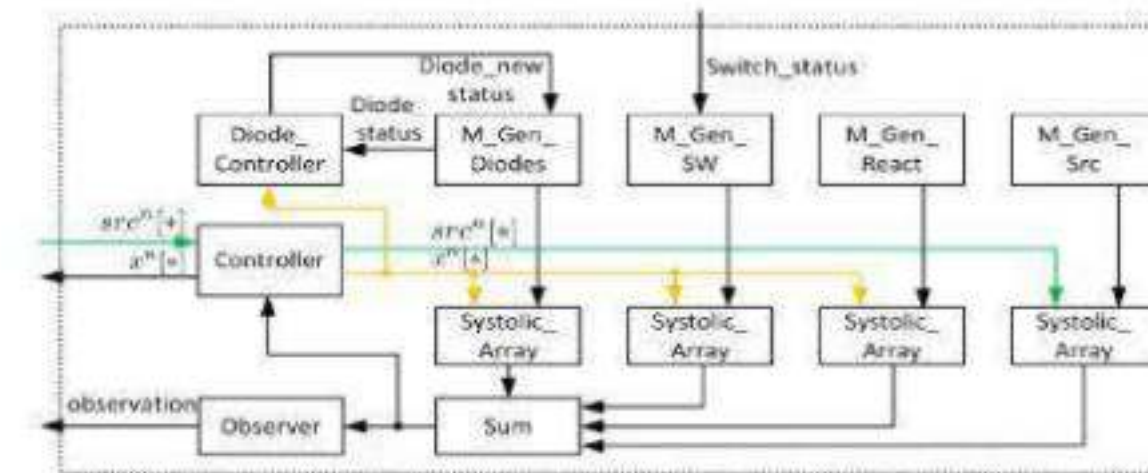

Systolic MNA Calculations Flow Chart

Design of PCS

The Process of Designing the Converter is as Follows:

- 1) Determining the Input and Output Parameters
- 2) Calculating the Component Values & Comparing with PEDA
- 3) Creating an Open Loop Simulation
- 4) Building an Open Loop Circuit on Breakaway board
 - a) Inverter
 - b) LLC Resonant Tank
 - c) Transformer
 - d) Rectifier & Output Filter
- 5) Creating Closed Loop Simulation
- 6) Designing PCB
- 7) Implementing the PCS's as Modular Blocks on the (4s) and (6s) drones

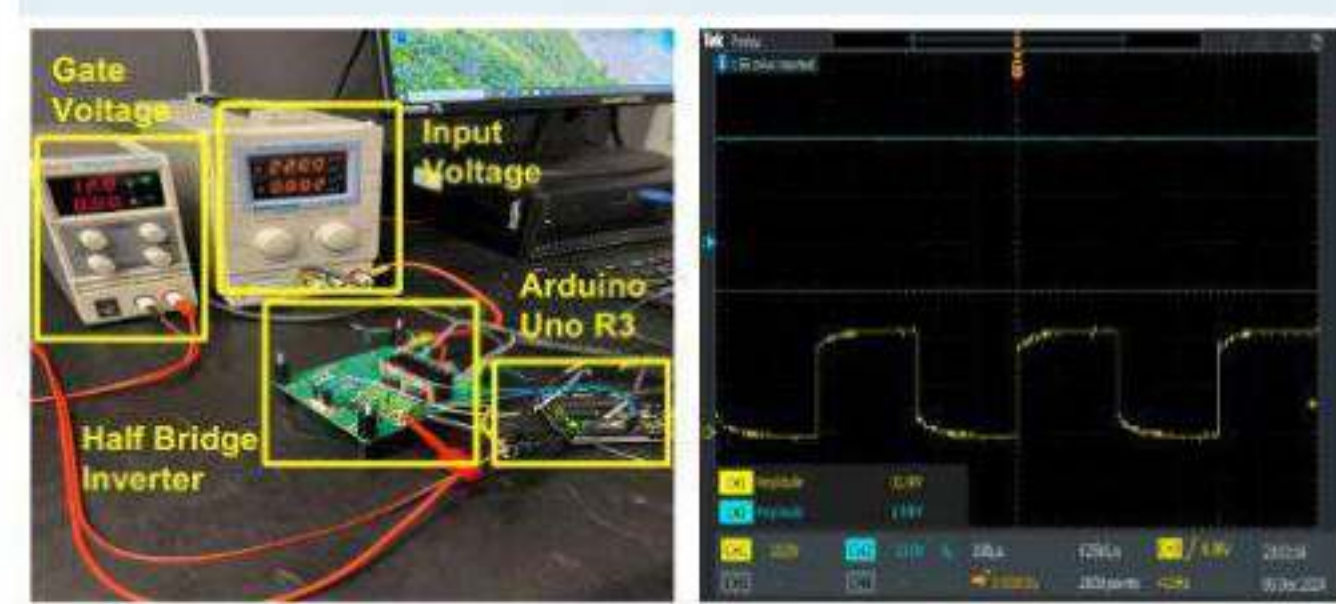

Inverter Stage

Inverter Input / Output Waveforms

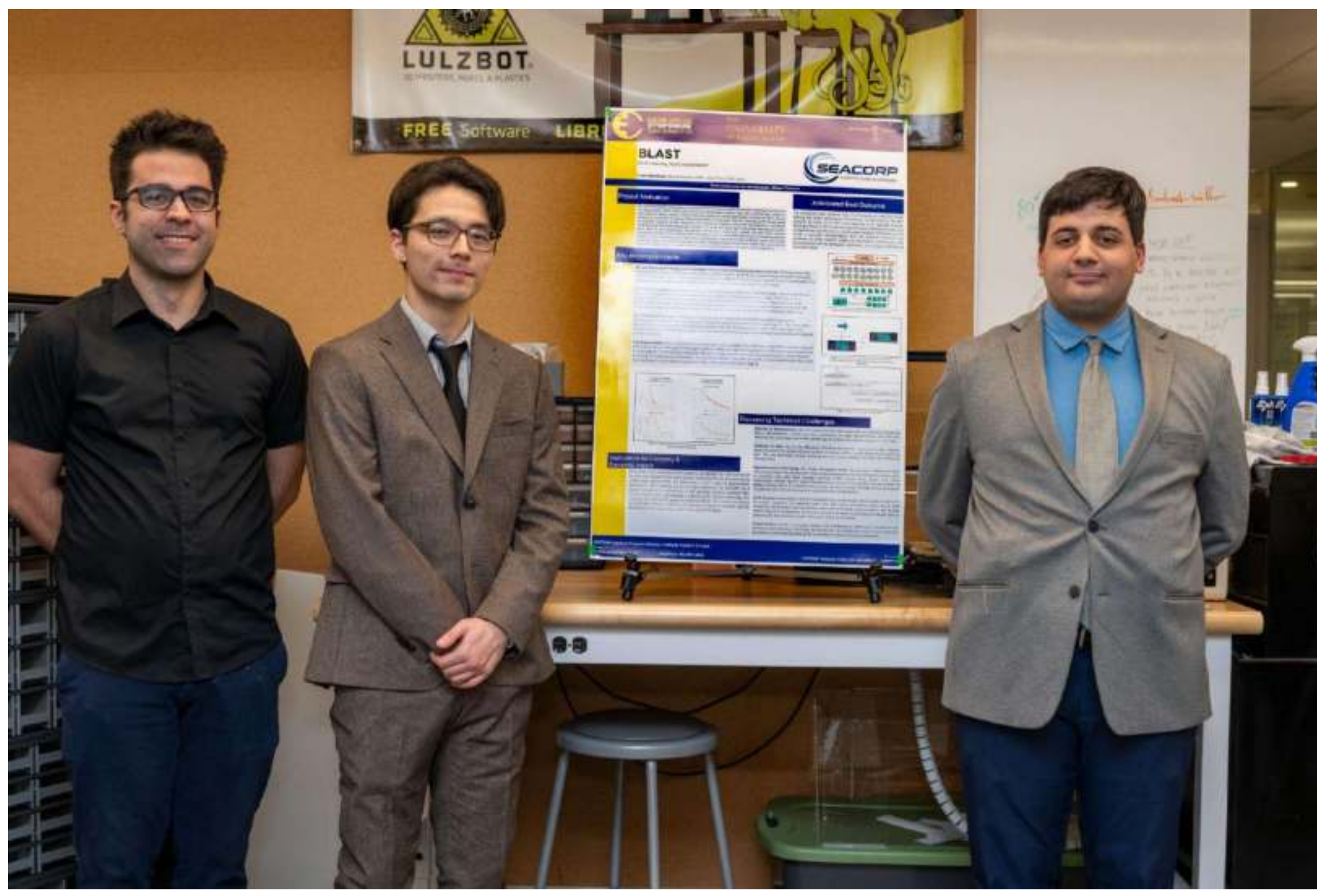

ELECOMP CAPSTONE SYMPOSIUM
TUESDAY, DECEMBER 19, 2023

THE UNIVERSITY OF RHODE ISLAND

THINK BIG WE DO™

BLAST

Burst Learning Audio Spectrogram

Team Members: Shuichi Kameda (CPE), Jakob Porto (CPE, CSC)



Technical Director(s): Bill Matuszak | Megan Chiovaro

Project Motivation

For end-to-end audio classification, convolutional neural networks (CNNs) have been a dominant architecture for many models. While CNNs were considered indispensable, they do have their shortcomings, notably in their ability to capture global context in data. By utilizing the Audio Spectrogram Transformer (AST), we can improve on the results of previous CNN-based models in many ways. The first is through performance; based on available research, an AST model has the capacity to produce state-of-the-art predictions, sometimes outperforming CNN-based approaches. Another is through the capturing of long-range dependencies within data, which is done dynamically through the self-attention mechanism. Overall, the AST model displays remarkable promise for the field of audio classification. Even so, SEACORP believes we can improve upon the model through fine-tuning, which if done for a specific task, may produce highly effective results. By utilizing these advantages with transfer learning, we seek to design an audio classification model that can show the potential for application in multiple scenarios, such as anomaly detection and sound event localization.

Anticipated Best Outcome

The anticipated best outcome sees us developing an effective model utilizing the Audio Spectrogram Transformer as described in the MIT research by Gong et al. The main objective is to leverage transfer learning to tune an AST model to a specific audio classification task, such as Right Whale identification or similar audio analysis. Ultimately, we will create a portable demonstration that the technical directors can showcase to other industry leaders in the field at conferences. This demonstration will be somewhat interactive, on a subject relevant to SEACORP's field.

Key Accomplishments

AST and Spectrogram Background Knowledge: Given our very limited prerequisite knowledge of machine learning coming into the project, there was much that we needed to learn. Most of our understanding of the AST framework came from the MIT research paper published by Gong et al (Fig. 1). Additionally, we needed to learn raw waveform-to-log-Mel spectrogram conversions (Fig. 2), which is the input format required for the AST model.

Training Environment: Transformers, which are the underlying architecture of the AST model, require a significant amount of computational resources to properly train. Several hardware options (i.e., GPUs, TPUS, etc...) were considered, but we ultimately discovered the University of Rhode Island's Unity Cluster. This resource is a high-performance computing cluster that provides access to industry-level processors and accelerators for no cost. We integrated our work with the cluster, letting us easily finish heavy training workloads at more reasonable times.

AST Framework Prototype: A working prototype of the AST model was developed using the Hugging Face Transformers API (Fig. 3). This involved pre-processing an audio dataset into log-Mel spectrograms. The inputs were then split into smaller patches and pushed through the main AST training pipeline, where the model learns the necessary details for classifying the audio. The prototype is currently capable of producing a classification with decent (70-80%) accuracy.

Data Augmentation: Due to the limited amount of audio data available, it is necessary to enrich the available datasets with augmentations. We used several augmentations within our augmentation pipeline, including frequency and time masking (Fig. 2). These masking techniques fall under a more general approach called SpecAugment, which involves modifying the spectrograms themselves. As a result, the model is less likely to overfit, or learn patterns specific to the training dataset, and can better generalize to data it has never seen before (Fig. 4).

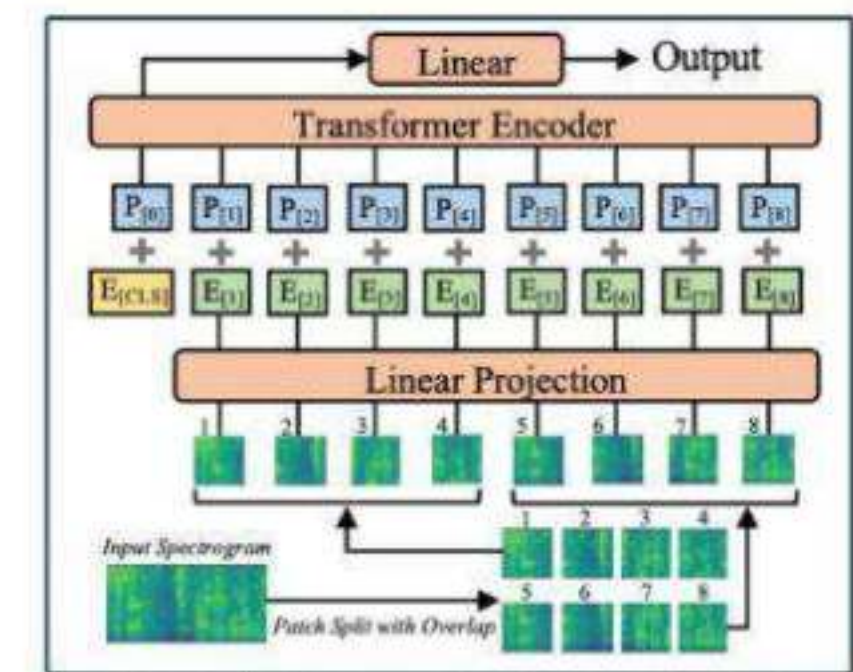

Fig. 1: Audio Spectrogram Transformer architecture

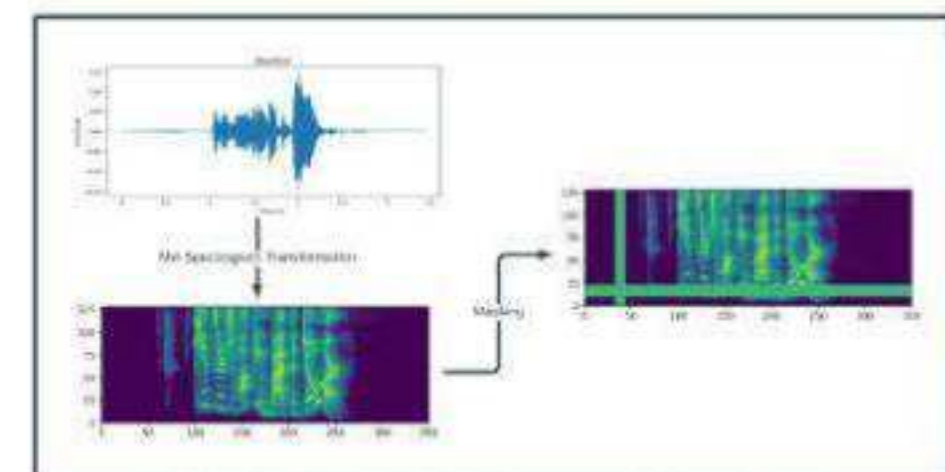

Fig. 2: An example of a waveform-to-Mel-spectrogram transformation, with an application of time and frequency masking

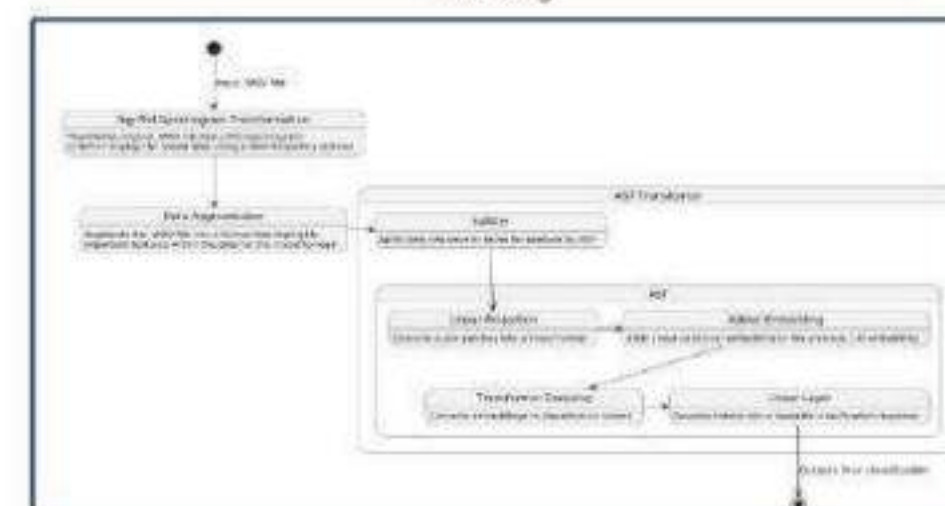

Fig. 3: Diagram of framework prototype

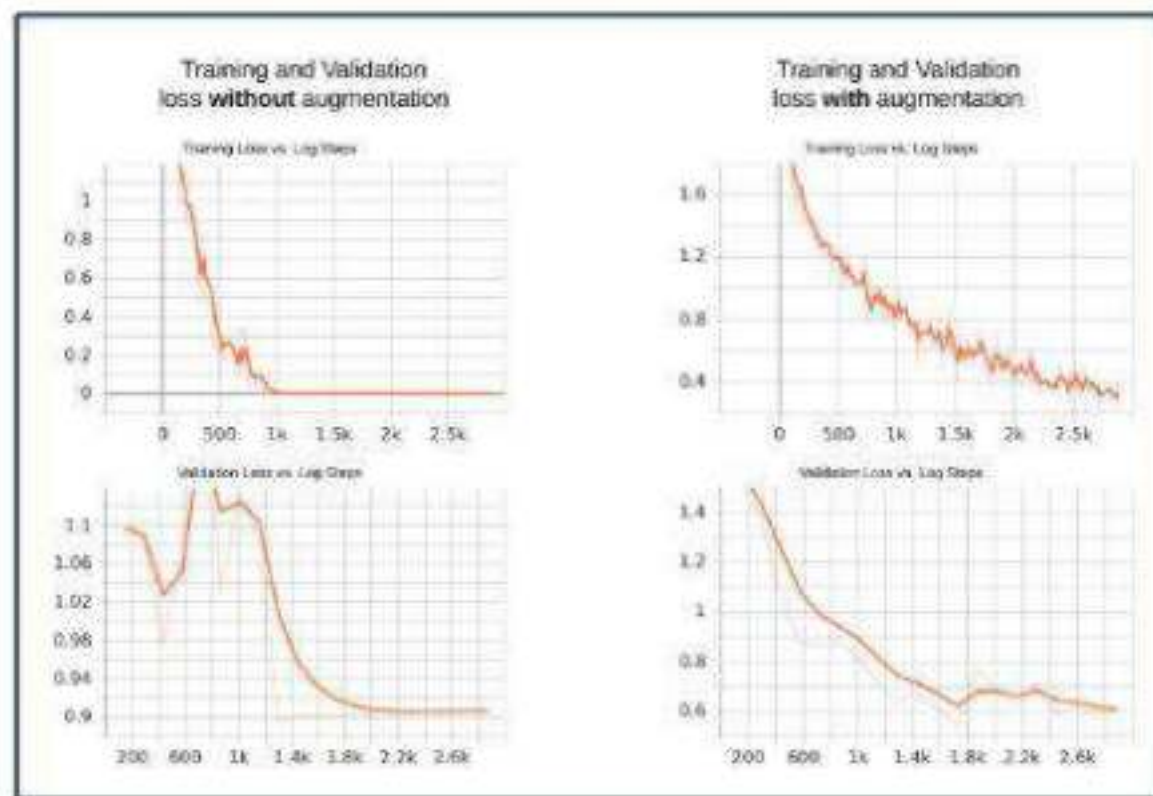

Fig. 4: Comparison of loss trends between non-augmented data and augmented data

Remaining Technical Challenges

Selection of Demonstration: We will continue to hold discussions with our technical directors to find a demonstration suitable for their conference. An ideal demonstration will effectively showcase the technology used while maintaining interactivity and holding relevance to the field.

Collection of Data: Due to the difficulties of finding high-quality, open-source audio datasets, especially within the domain of naval warfare or marine wildlife, we will likely need to build our own. This will potentially involve capturing our own audio, labeling the data, and setting up metadata files.

Hyperparameter Fine-Tuning: The model will require further fine-tuning to improve the final inference accuracy. This process will involve continued analysis of several evaluation metrics, such as accuracy, loss, and mean average precision (mAP), among many others. From these observations, we will need to adjust hyperparameters such as the learning rate and number of epochs, among others. To streamline this process, we plan to utilize methods such as grid search to systematically find the most optimal hyperparameter configurations.

Audio Receiver: Depending on the final functional form of the project, we will need to determine the proper equipment for capturing audio. This will involve researching which devices have satisfactory specifications that can perform well under potentially noisy conditions. We will also need to take into consideration the device's potential for signal processing since we will need to capture audio that maintains a high clarity up to 16 kHz for the model.

Output Handler: Similar to the audio receiver, this will depend on what route is decided for the conference demonstration. As of now, we believe that the classification output of the model will be pushed to some interface that will be presentable to whoever it is interacting with.

Implications for Company & Economic Impact

One of the main objectives of the project is to highlight the effectiveness of transfer learning within the audio domain. Achieving this has the potential to unlock new opportunities for addressing a wide range of audio-related applications. This outcome would be highly beneficial for SEACORP, as it would strengthen its positioning in the growing machine learning (ML) market. Additionally, by possessing a superior audio analysis technology, the company will increase its appeal to potential clients. This creates an avenue for SEACORP to secure additional AI contracts, helping to establish itself at the forefront of cutting-edge machine learning technologies.

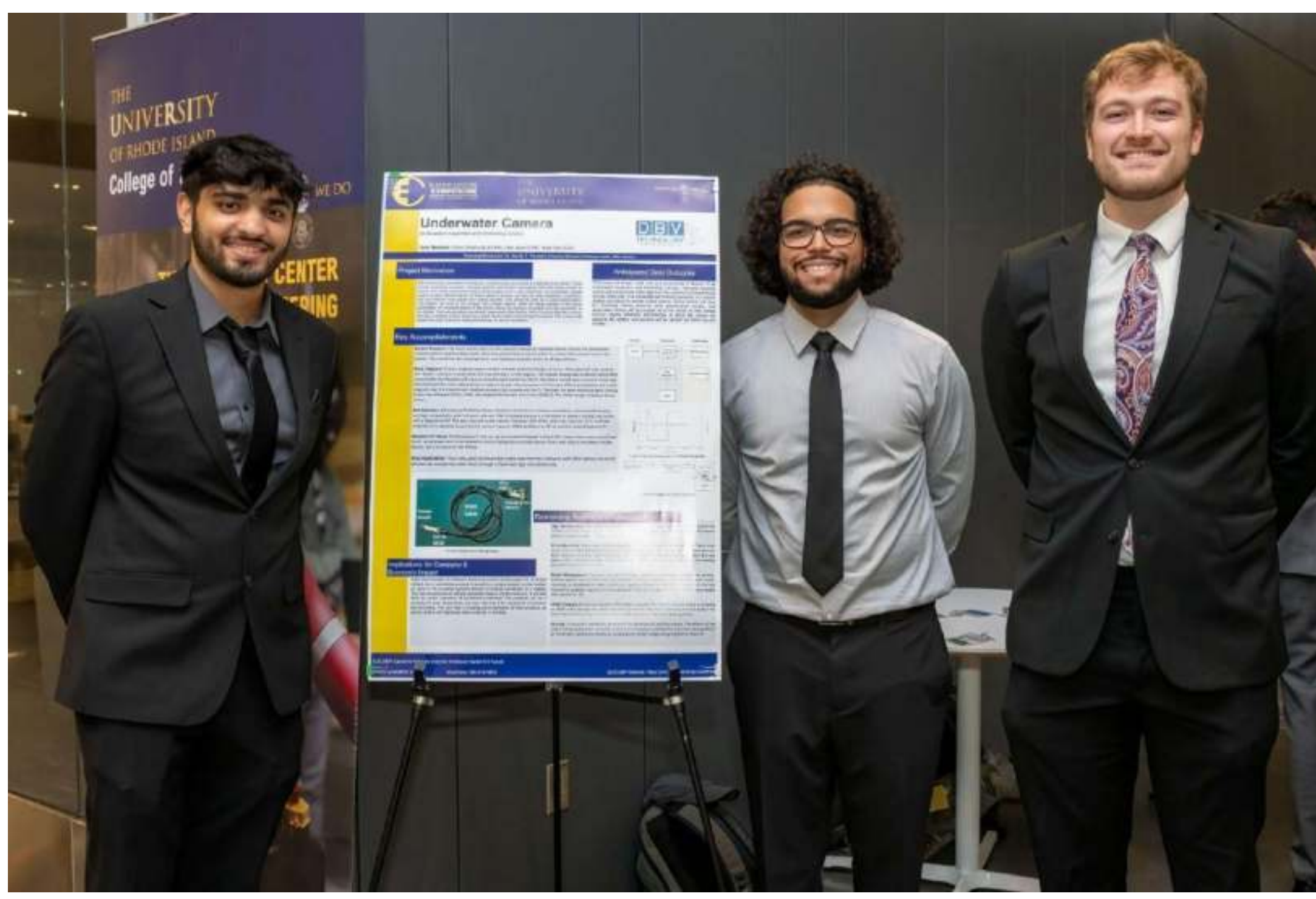

ELECOMP CAPSTONE SYMPOSIUM
THURSDAY, DECEMBER 19, 2024

THE UNIVERSITY OF RHODE ISLAND

THINK BIG WE DO™

Underwater Camera

Underwater inspection and monitoring camera

Team Members: Ishan Chadha (ELE/CPE), Jake Javier (CPE), Noah Sarji (ELE)



Technical Director(s): Dr. Harold T. Vincent II | Connor Vincent | Zachary Lindo | Mike Smith |

Project Motivation

DBV Technology specializes in designing, manufacturing, and operating underwater instruments. These include underwater acoustics, recovery systems, and custom instruments. With this comes a need to monitor and observe equipment that is being tested, or is in use. Oftentimes, an underwater camera system is used. Market options for these systems do exist, but they are often expensive, proprietary, and fully tethered. They usually don't attach to poles. Thus arises the need for a custom-built system. This system will have to be cheaper than market options, while still being capable of the same functionality. An important feature of the system will be the wireless connection from the transmitter to the display. Commercial options are directly connected to the display, which hampers flexibility in setup and use. A wireless system allows for a stable display while maneuvering the camera. This custom built system will assist in product deployment/testing, as well as inspections.

Anticipated Best Outcome

The team will design, build, test, and demonstrate 2 versions of an Underwater Inspection and Monitoring Camera. The pole mounted version will transmit live video data from the camera to a transmitter at the top of the pole. This transmitter will connect wirelessly to a topside display, and allow for remote control options. These options will allow for recording, taking pictures, and pan-tilt-zoom control. The suspended version will accomplish all of the above as well, except function slightly differently mechanically. A winch like device will suspend the system, and weights will be needed for balancing and stability.

Key Accomplishments

Market Research: The team started with market research, analyzing available market options for underwater camera systems and how they work. All of the systems found used a tether to connect the camera feed to the display. They tended to be very expensive, and marketed towards divers as diving cameras.

Block Diagrams: 5 block diagrams were created to model potential design solutions. A Raspberry Pi was used as the "brains", taking in a video feed and transmitting it to the display. The topside display was a cellular device that connected to the Raspberry Pi via a wireless hotspot hosted by the Pi. The device would have a custom made app that displayed the video data and some buttons for pan-tilt-zoom control. The main difference between the block diagrams was the transmission method between the camera and the Pi. The ones the team looked at were Analog, Power over Ethernet (PoE), HDMI, and Gigabit Multimedia Serial Link (GMSL2). The HDMI design ended up being chosen.

Part Selection: A Raspberry Pi 4 Model B was chosen as the Pi for its wireless capabilities, decent performance, and high compatibility with 3rd party add-ons. The Pi camera module 3 is the latest Pi camera module and works with a Raspberry Pi 4. This was selected as the camera. Standard 10ft HDMI cable was selected. 2 CSI to HDMI modules were selected to convert the camera input to HDMI, and back to CSI to connect to the Raspberry Pi.

Raspberry Pi Setup: The Raspberry Pi was set up as a wireless hotspot. Using a VNC viewer, the camera feed from the Pi camera was able to be viewed on both a laptop and a mobile device. There was little to no latency on the laptop, but a lot more on the iPhone.

Web Application: Flask was used to stream live video over the local network with little latency. Multiple devices can access the video feed through a flask web app simultaneously.

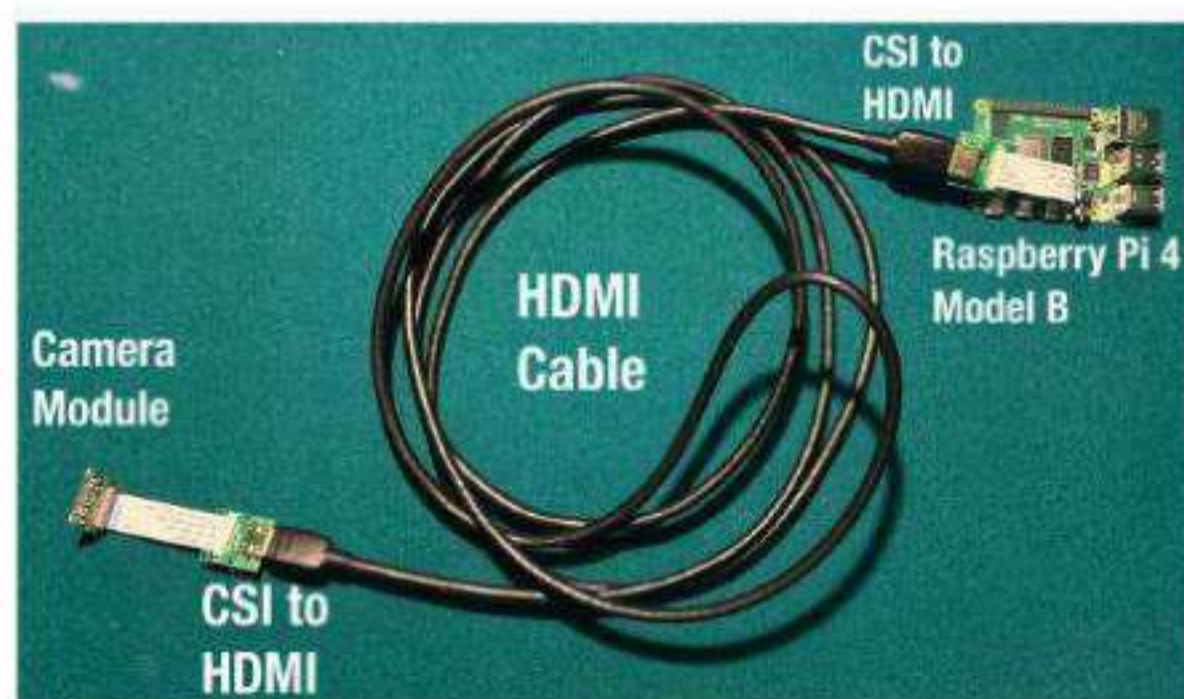
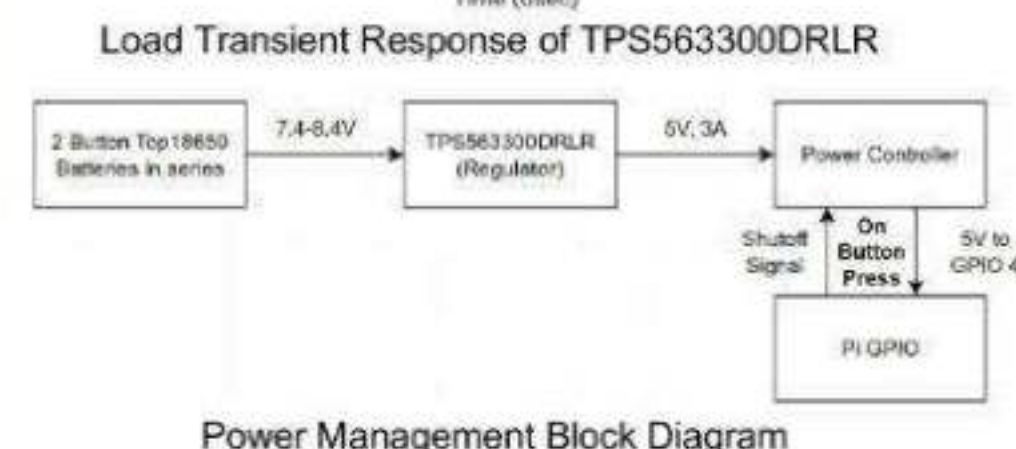
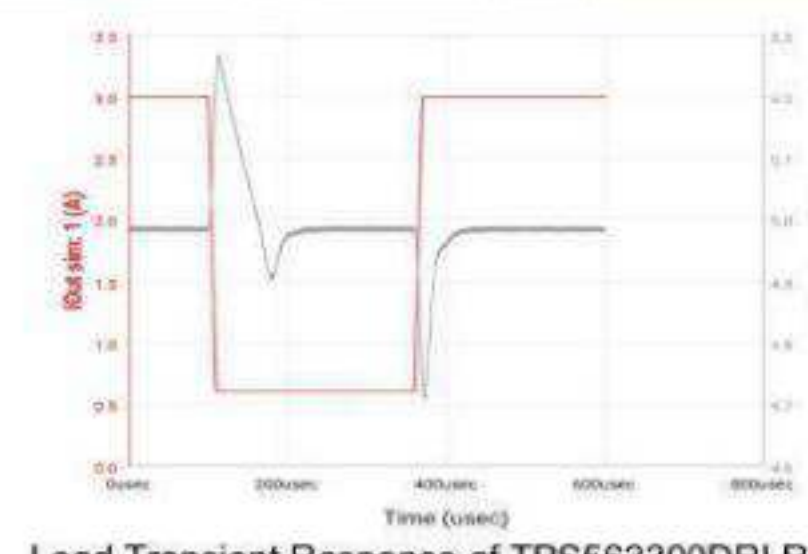
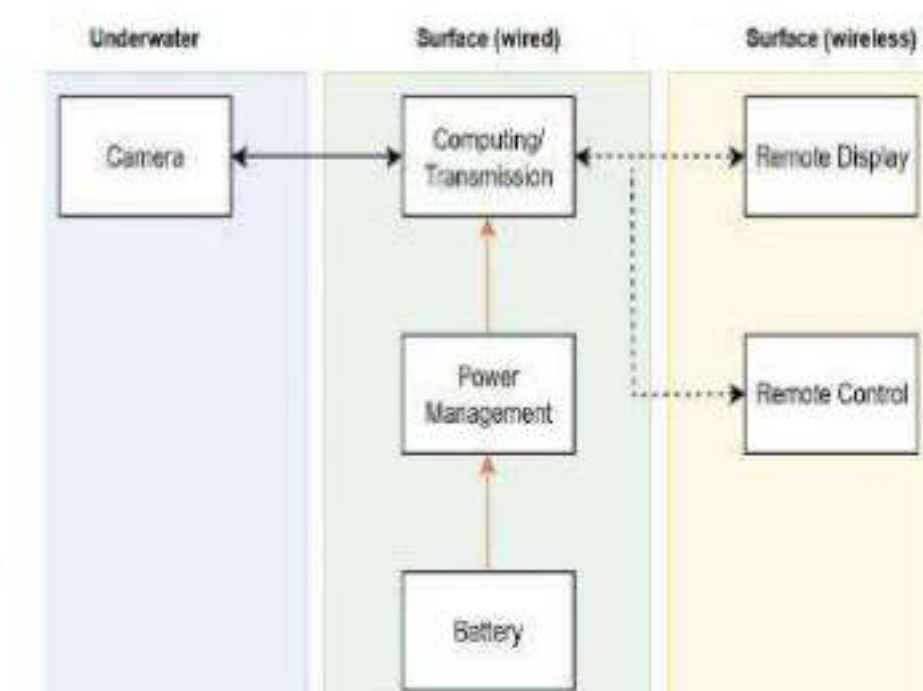

Current design and testing setup

Remaining Technical Challenges

App Development: The team found that it is best to make a web interface to interact with the camera. For the prototype we are just looking for basic tools i.e a display screen and a record button. Interaction with the app is to be added.

Pi Configuration: The current configuration of the Pi is not suitable for mobile devices. There is too much latency when viewing the live feed. A potential solution is to stream the video feed over the local network using the Flask framework. This would involve creating a web application that any device with a browser can use. Other options are creating a custom built application and sending the video feed to it from the Pi.

Power Management: The team has yet to develop a power management system for the project. Market options are available for this, however we have decided to go with a custom model. Currently, a rechargeable 18650 lithium ion battery is being considered for the system. This will connect to a voltage regulator circuit and shutoff circuitry to supply the Pi and the camera module with around 5V, 3A.

HDMI Crimping: An end terminated HDMI cable is needed. The plan for waterproofing is stripping an HDMI cable, passing the naked wires through the housing, and terminating it at the end on the other side of the housing. The end will be sealed to prevent water from getting inside.

Housing: A housing is needed to waterproof the Raspberry pi and the camera. The effects of the system being underwater cannot be tested until a housing is created. This can have varying effects on the project, potentially leading to scrapping the current design and going with a new one.

Implications for Company & Economic Impact

If the best outcome is achieved, there is a chance for the project to be further refined into a marketable product. It would be a unique product on the market, as none of the available systems feature a wireless connection to a display. This has the potential to directly generate revenue for the company. It will also allow for easier inspection of equipment underwater. The company will use it primarily for boat inspections, but may also use it for equipment inspections and recording. This can help in creating advertisements for their products, as well as testing and deploying these products in the field.

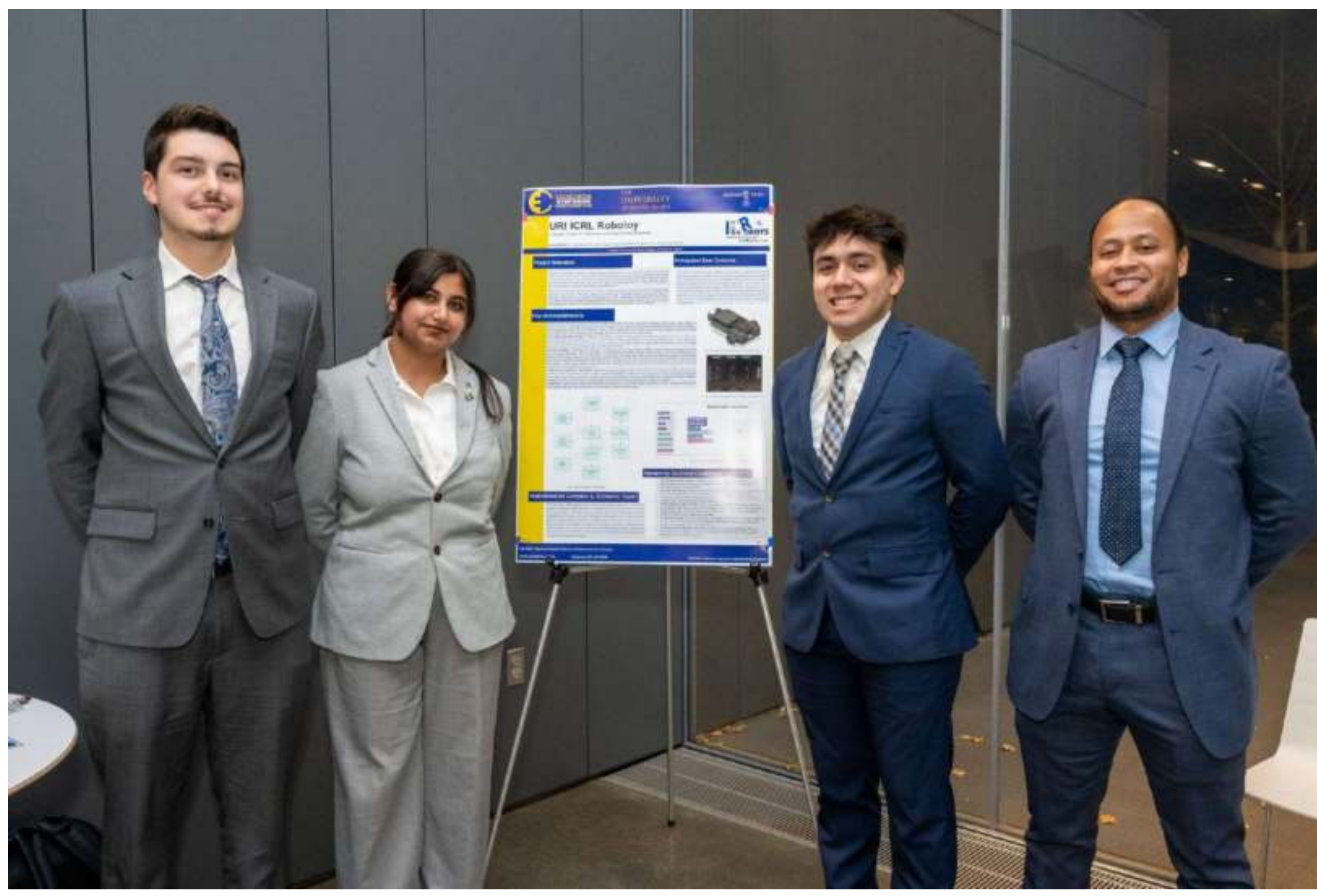

ELECOMP CAPSTONE SYMPOSIUM
THURSDAY, DECEMBER 19, 2024

THE UNIVERSITY OF RHODE ISLAND

THINK BIG WE DO™

URI ICRL Robotoy

A Robotic Toy for K-12 Robotics and Programming Exposure



Team Members: Argha Goswami (CPE), Andrew Rae (CPE), Ryan Bolanos (ELE), Thomas May (ELE)

Technical Directors: Dr Paolo Stegagno & Cameron Amaral

Project Motivation

Exposing young Rhode Islanders to programming and robotics is a way to promote access to well-paying jobs and other opportunities. Additionally, increased participation of people from under-represented groups could also promote diversity in the field, and ultimately result in an increase in the total number of workers. The ICRobots lab is partnering with the URI College of Engineering (COE) to bring STEM programs focused on robotics to schools across Rhode Island from K-12.

RoboToy is being especially developed to fill the need for students in early education (K-5). Programming inherently requires basic skills like reading and math that are still being acquired in the early stages of education, which add to the burden of learning new skills. Graphical programming tools have been developed to introduce foundational programming concepts in an easier setup, but they still lack the contact and manipulation experience provided by physical toys, which is fundamental in early childhood.

Anticipated Best Outcome

The Anticipated Best Outcome (ABO) of this project is a fully functional and replicable prototype of a single robotic kit with a ground robot and coding blocks to be delivered to K-5 classrooms around Rhode Island. The robot should be powered by regular AA batteries and integrate 2 ultrasonic sensors and one sound sensor. It must be able to read a sequence of up to 12 blocks inserted into a slot on its back, with each block representing commands such as go forward, backwards, right, left, stop, as well as implementing for-loops and if-statements. Each block should also be visually different in a way that can be easily recognized by illiterate users.

Key Accomplishments

- **Body Design:** A panda design was selected in order to make RoboToy more aesthetically pleasing and to entice young children to want to play with it. The body will consist of a lower baseplate (Fig. 1) which will contain the electrical components (microcontroller, motor shield, push button array PCB, sensors, motors), and an upper panda shell which will receive the command blocks and hold the power switch. The body is designed using Autodesk Fusion and will consist of 3D-printed parts.
- **PCB and Schematic Design:** A schematic was created, in order to incorporate the pre-made 4x4 button arrays into a full 8 x 12 button array. This was then transferred over, and created into a PCB design file (Fig. 2). The current design has 6, 8 pin connectors, which will each attach one 4x4 button array. Custom 3D printed standoffs will also be integrated into the PCB, in order to prevent shorts and stress between the 4x4 button arrays and the custom PCB.
- **Firmware Design:** The firmware architecture is designed as a Finite State Machine (FSM) to ensure efficient management of the robot's states and transitions. Six core commands—Left, Right, Forward, Back, Wiggle, and a For Loop—have been implemented to enable versatile robotic behaviors. The firmware integrates logic for reading data from onboard sensors and managing a push-button array for user interaction and control. Improvements have been made to last year's codebase, optimizing performance and enhancing functionality by addressing inefficiencies and streamlining command execution. A defined list of commands is encoded into bit strings for efficient processing and communication.
- **Button Array and Power Regulation:** Significant progress has been made on the robotic toy car project, which is powered by a regulated 12-volt, 5-amp power source to ensure consistent and reliable operation for all components. Several key hardware elements have already been tested successfully. The big sound sensor and ultrasonic sensor are both operational, demonstrating their capability to integrate into the toy car's design. The button array has also been tested and confirmed to function as intended.
- **Simulation:** A preliminary simulation for the Robotoy model (Fig. 3) has been made using html,css and js integrated with Blockly. The simulation replicates all the movements of the model as well as the block stacks.

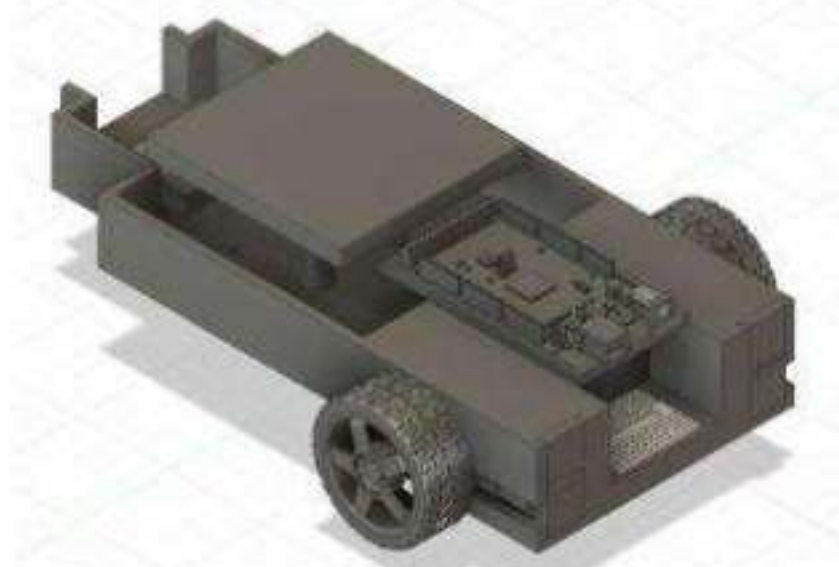

Fig. 1 Current base plate design in Autodesk Fusion.

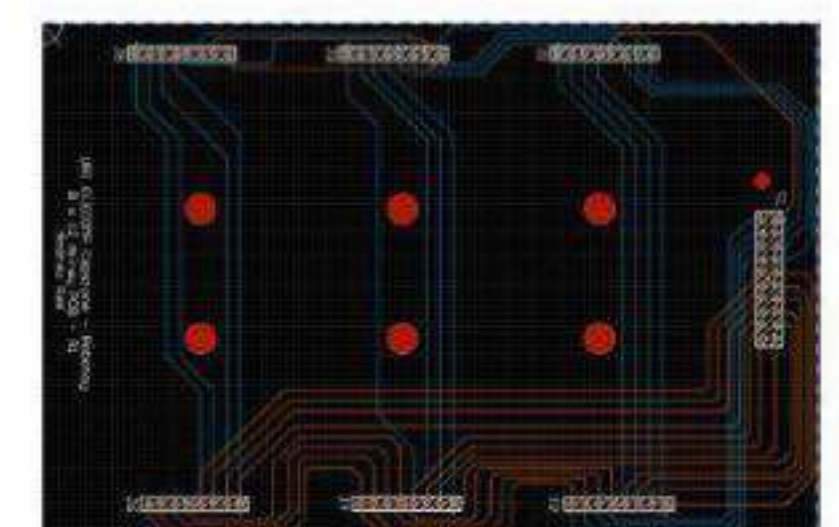

Fig. 2 Current design of custom PCB for button arrays.

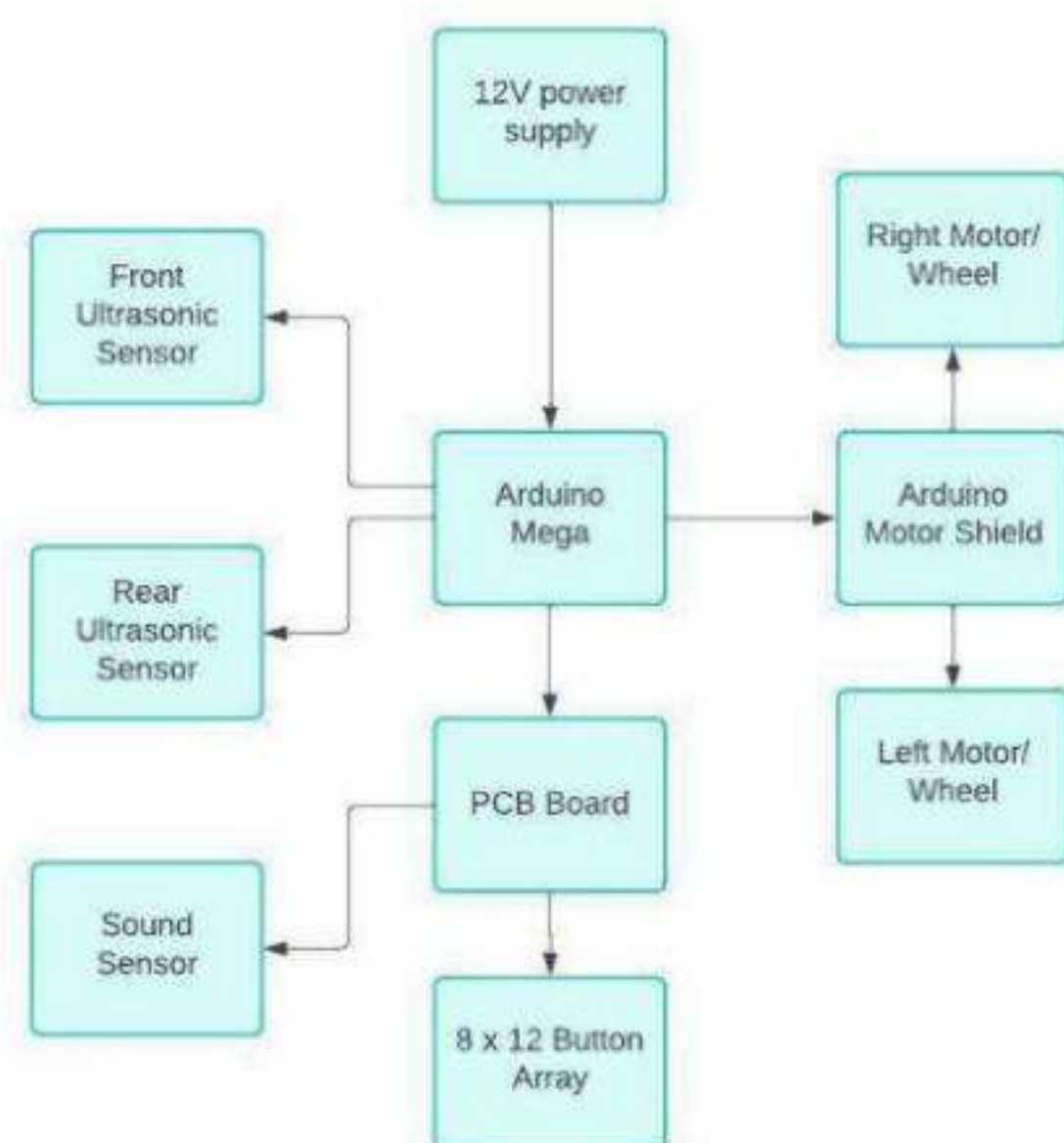

Fig. 4 Block Diagram of Robotoy

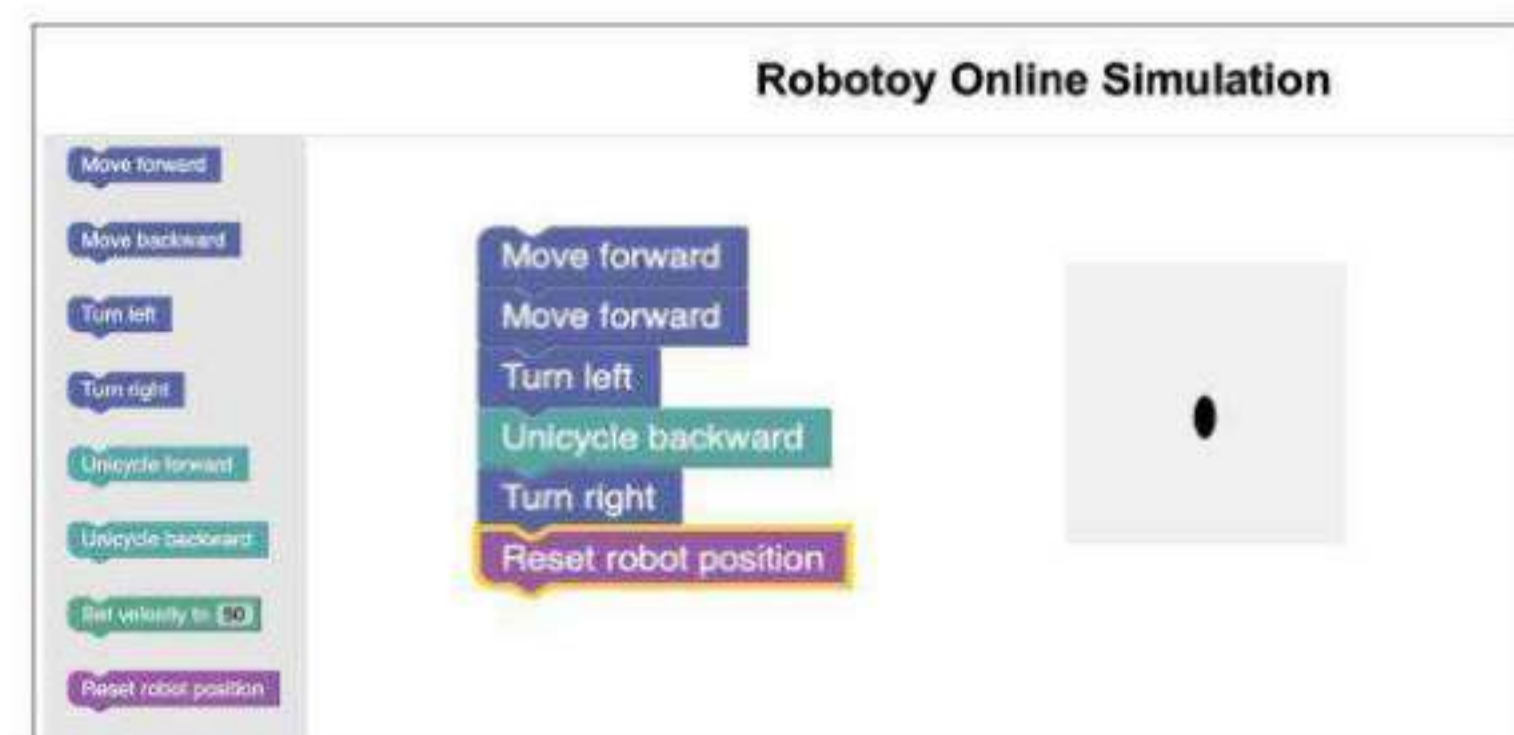

Fig. 3 Website Simulation of Robotoy with Blockly integration.

Implications for Company & Economic Impact

Providing early childhood exposure to robotics and programming in K-5 schools will improve and expand STEM education in Rhode Island, allowing students to take the first step towards a successful career in high-paying tech jobs. With RoboToy the ICRobots lab will inspire a generation of Rhode Island students and establish itself and URI as an internationally recognized research institution for robotics. This will allow those very same local students to continue their education and careers in Rhode Island, allowing Rhode Island to position itself as an international hub in the tech industry and improve its economic foundations. In the long term, this will attract a diverse population of high-quality students and workers.

Remaining Technical Challenges

- **Command Block Design:** Command blocks must be designed to be able to fit smoothly into and attach to the panda shell and maintain constant pressure on the buttons of the push button array during operation.
- **Panda Shell Design:** Panda shell must be able to accommodate the command blocks and also provide ventilation in the case of any excess heat buildup from the electrical components. Panda shell or baseplate must also provide fixtures to hold all components in place so they do not break loose during operation.
- **Physical integration of PCB:** At the current state, our PCB is almost done with the design phase and will soon move to the verification and production phase. Once the PCB is physically made, we will be able to test it with both the Arduino hardware, and the software to detect which instruction is inputted.
- **Firmware Design:** Six core commands—Left, Right, Forward, Back, Wiggle, and a For Loop—have been implemented, but additional functionality remains to be added. This includes incorporating if-else command blocks.
- **Simulation Development:** Integrating microphone and audio components into the simulation poses a significant challenge, requiring careful planning to ensure accurate replication of real-world interactions.

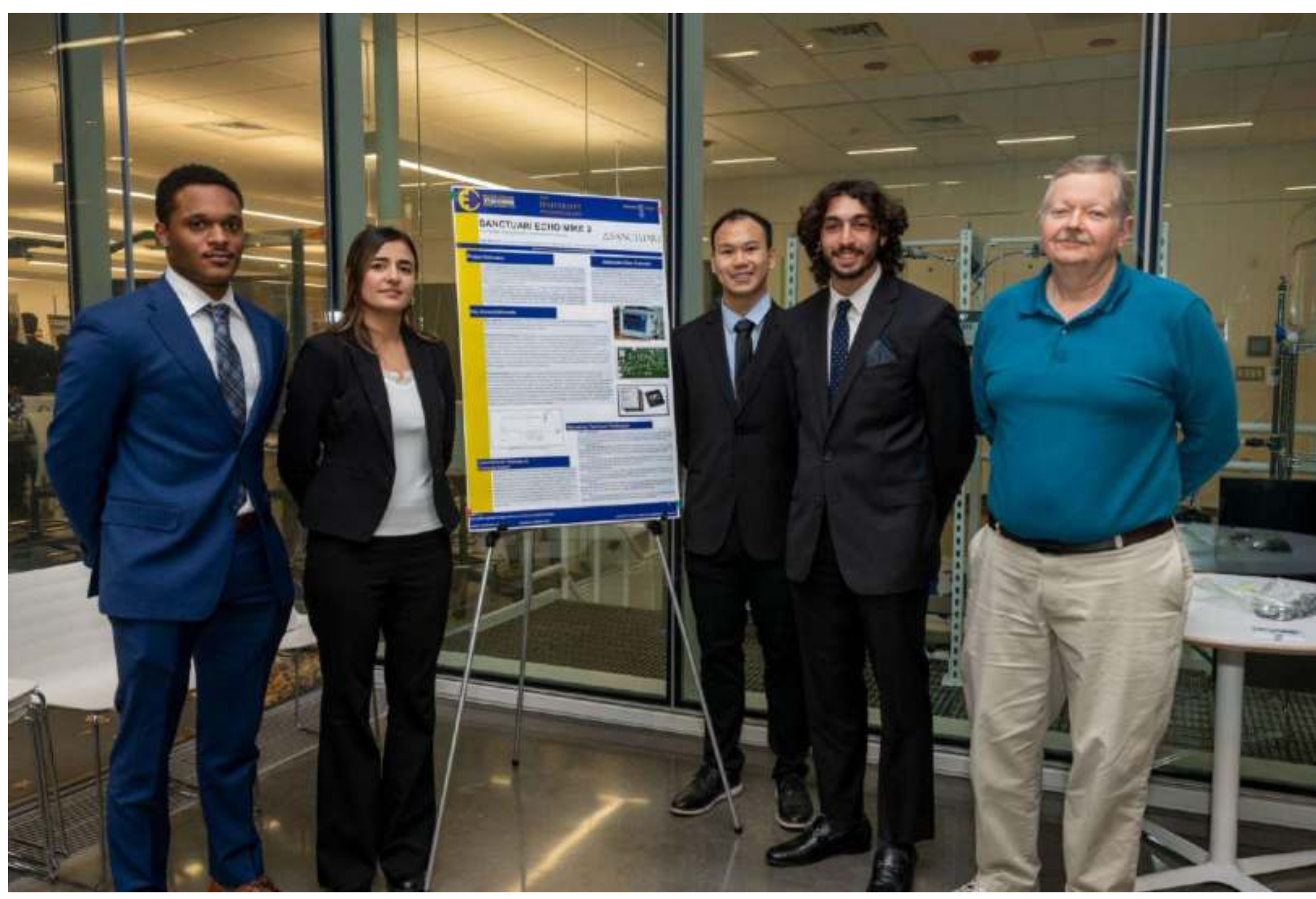

ELECOMP CAPSTONE SYMPOSIUM
THURSDAY, DECEMBER 19, 2024

THE UNIVERSITY OF RHODE ISLAND

THINK BIG WE DO™

SANCTUARI ECHO MIKE 2

Post-Release Tacking Device For Small Mammalian Species



Team Members: Jack Russo (ELE), Ismail Muhammad (ELE), Barry Huang (ELE), Amani Hameed (CPE)

Technical Director(s): Joe Moreira and Chris Rothwell

Project Motivation

Wildlife rehabilitators face the challenge of losing contact with animals after their release, making it difficult to monitor survival and behavior. This lack of information hinders efforts to ensure the success of rehabilitation programs and to gather vital data. Post-release tracking devices offer the potential to enhance wildlife survival rates by providing real-time insights into animal movements and well-being. However, existing technologies, including GPS and satellite telemetry, are often too large, costly, or inaccessible for smaller species.

The Echo Mike 2 project aims to address this critical gap by developing a compact, lightweight, and energy-efficient tracking device specifically for smaller mammals. By integrating modern communication technologies, such as Bluetooth and cellular networks, and innovative power management solutions, the device will provide rehabilitators and conservationists with essential data. This advancement will improve animal care and release strategies while supporting broader conservation efforts, ensuring ecological sustainability and better wildlife recovery programs globally.

Anticipated Best Outcome

The anticipated best outcome is the successful design, prototyping, and testing of a compact, lightweight, and ergonomic tracking device with a long battery life, optimized for small mammalian species such as foxes, raccoons, rabbits, and much more. The device will feature GPS and Bluetooth technology for accurate location tracking and data transmission, along with optional sensors for monitoring animal health. Designed for reliability in different environmental conditions, it will include customizable settings to optimize performance and power efficiency. The tracker will address the specific needs of wildlife rehabilitators, ensuring effective post-release monitoring and improving the overall chances of animal survival.

Key Accomplishments

Main chipsets: On the hardware side, we analyzed possible components and selected main chipsets to use for the project. The two main components in the system are the silicon labs EFR32MG24 microcontroller and the Quectel BG77 IoT module.

PCB Schematic and Layout: For this project to be successful, the tracking device must be small enough for smaller animals to carry comfortably. To meet this requirement, we designed a custom PCB tailored to these size constraints. Our development process relied heavily on the datasheets for the BG77 and BG24, as well as the corresponding development kits, to identify and integrate the necessary components. This process also accounted for both hardware and software considerations to ensure compatibility and functionality. By dedicating significant time to thoroughly studying the datasheets, we minimized the risk of errors during schematic development. Using resources provided by Quectel, Digi-Key, and RAK, we successfully created the essential components and integrated them into a compact, efficient design. This will lead us into the PCB layout.

Firmware/software: we have begun our app development and enabled EUSART one for sending commands to the BG77 allowing GPS positioning. The app has a framework put in place for BLE communication and we have planned a method for sending our configuration settings and commands to the device over BLE connections. We have a separate app for smartphones made to connect and send this data being developed in parallel. Another UART is being configured to receive data back from the BG77. Most of the development to date has been centered on ensuring proper utilization of the EUSARTs and an easy set of functions for sending commands to the BG77. We believe that a full understanding of the system will help us build it up with more detail and foresight so we have made a functional block diagram to give us a clear idea of the design needed.

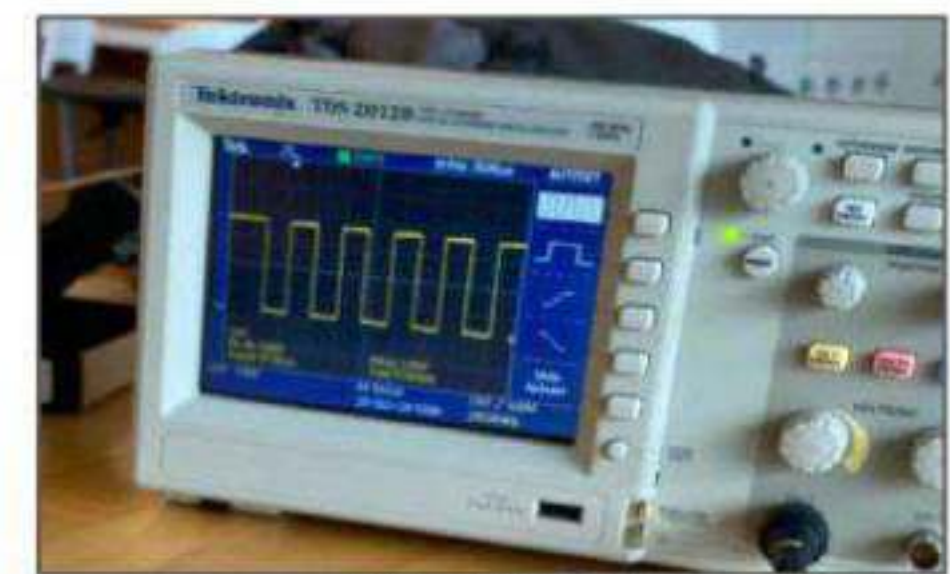

UART signal testing

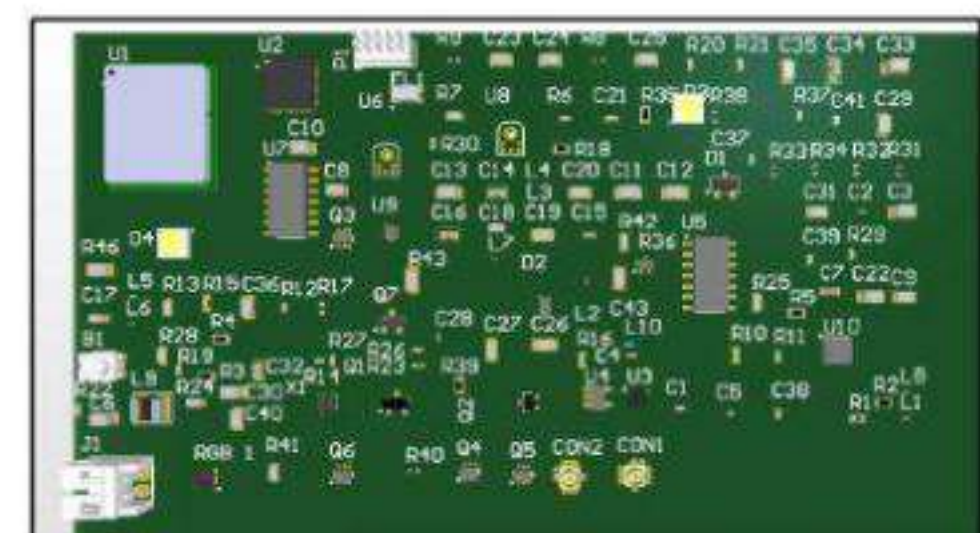

All PCB Components



BG77 & BG24

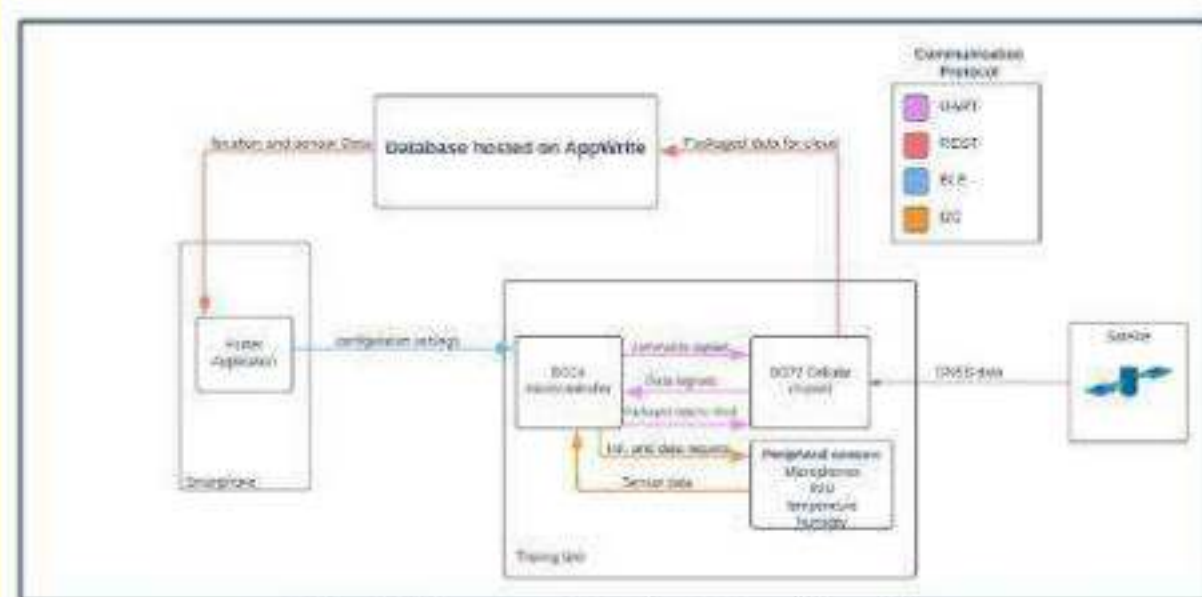

Block Diagram of Project Functionality

Remaining Technical Challenges

Tracker Functionality:

We will focus on debugging and ensuring reliable communication between the BG24 and BG77 chips. This will involve implementing periodic wakeup cycles, GPS tracking, cloud data transmission, and integrating additional sensors for enhanced data collection and monitoring.

Energy Management:

We will prioritize power conservation by developing strategies to reduce energy consumption. This will include testing the firmware, configuring the boards to enter power-saving modes, and ensuring that essential functionality is maintained while minimizing power usage.

Backend Development:

Our efforts will focus on setting up and configuring the backend infrastructure to handle real-time location data. We will ensure that data is processed efficiently and stored securely, allowing for seamless integration with other system components.

Cross-Platform App Development:

We will build and test a cross-platform Flutter app that integrates with the backend for real-time updates. The app will allow users to configure and monitor the tracker via Bluetooth Low Energy (BLE), providing a user-friendly interface for mobile platforms.

Tracker Housing:

We will optimize the housing design to minimize size and weight while ensuring durability and an IP67 rating for water and dust resistance. The design will also focus on ergonomics, making the device more comfortable and easier to handle in different environments.

PCB Design:

We will finalize the development of the components for the BG77 and BG24, ensuring that all connections are correctly organized and integrated into the PCB design.

Implications for Company & Economic Impact

As a nonprofit organization, SANCTUARI prioritizes the successful rehabilitation of animals over financial considerations. The completion of the Echo Mike 2 design will provide a groundbreaking data collection tool, filling a critical gap in the final stages of animal recovery. This innovative device will offer valuable insights into post-release behavior and survival, enabling caretakers to monitor animals' progress more effectively. By offering a complete picture of an animal's recovery, tracking its behavior, and identifying potential complications or the need for extended care, the tracking device will significantly enhance the rehabilitation process, improve outcomes, and support SANCTUARI's mission of wildlife conservation.



THE UNIVERSITY OF RHODE ISLAND



AI/MV for Wildlife Rehabilitation



A 501(C)(3) NONPROFIT FOR WILDLIFE

Team Members: James DeMello (CPE), Van Davey (CPE)

Technical Director: Joe Moreira

Project Motivation

There is a pressing shortage of wildlife rehabilitators to care for animals in need, leading many to feel overwhelmed and unable to provide optimal care. This project seeks to address this critical issue through the application of Machine Vision and Artificial Intelligence (MV/AI) technologies. Through such advancements, we can significantly enhance wildlife rescue, rehabilitation, and veterinary practices.

SANCTUARI has amassed nearly 0.75 petabytes of valuable, mission-critical video footage. The goal of this project is to intelligently filter this footage to extract relevant animal content, which will then be used to develop AI systems integrated with video monitoring. These systems will greatly improve the capacity and diagnostic capabilities of wildlife caregivers. Ultimately, the project aims to demonstrate various methods that will enhance care for wild animals, ensuring they receive the attention and treatment necessary for their recovery and well-being. Through these innovations, we hope to reinforce support for wildlife rehabilitation efforts.

Anticipated Best Outcome

To achieve the ABO, at least 3 of the following 6 objectives must be completed:

- Design a system for filtering the most relevant video records provided.
- Apply the filtering system to all video files.
- Create a separate system to utilize videos that pass the filtering process.
- Train and test an AI system using the filtered videos, designed for monitoring purposes.
- Deploy the trained AI as live video monitoring "virtual helpers" for wildlife caregivers.
- Enhance efficiency and effectiveness in wildlife care through improved video analysis and support.

Key Accomplishments

Executable File: Designers made an executable Python file capable of taking file metadata from a specific folder or whole drive and exporting that data to Excel. Due to issues with the thumb drive, debugging was necessary to make the file executable no matter the computer attached. After fixing the executable, it worked flawlessly, and a guide was made for easy use.

Machine Learning (ML) Model Selection: The YOLOv10 architecture was selected for our application due to its robust performance in object detection and feature extraction, making it ideal for analyzing complex visual data. Built on a Convolutional Neural Network (CNN) backbone, YOLOv10 processes entire images in a single forward pass, allowing it to detect and classify objects with exceptional speed and accuracy. Its ability to divide an image into grids and predict bounding boxes, object classes, and confidence scores enables it to efficiently identify features across various scales and contexts. For power data signatures represented visually, this architecture excels at capturing intricate spatial patterns and contextual relationships. By extracting these key features, YOLOv10 provides a reliable framework for understanding the underlying characteristics of the data, ensuring high precision and real-time performance.

ML Training Setup Formation: A training setup was designed to fine-tune the YOLOv10 architecture for adapting to data not included in the pretrained model. The process involves segmenting the dataset into training, validation, and test sets while using image masking techniques to analyze average RGB values of the environment at different times of the day. These masks provide contextual understanding of conditions, such as lighting and color variations, that can influence object detection accuracy. Users can define key parameters, including batch size, number of epochs, and input image dimensions, to tailor the training process. This setup optimizes the model for new datasets, enhancing detection capabilities under diverse environmental conditions.



AI Decision Tree

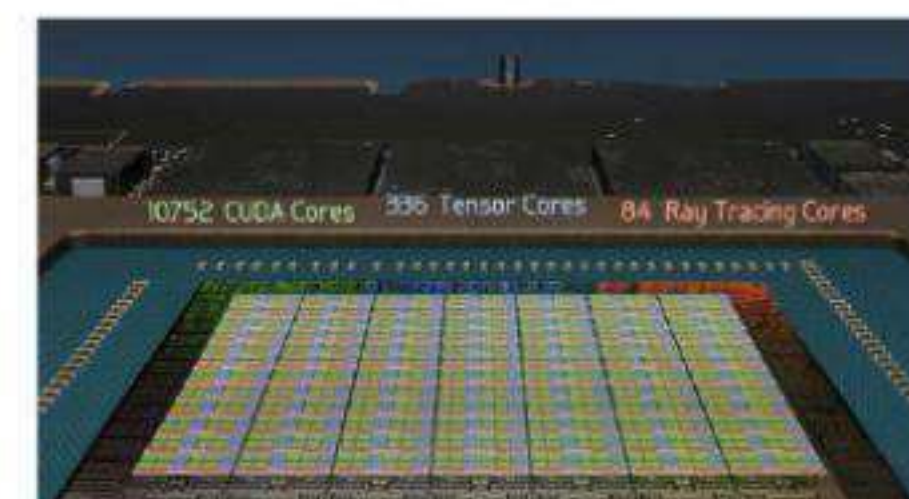

NVIDIA GPU Cores

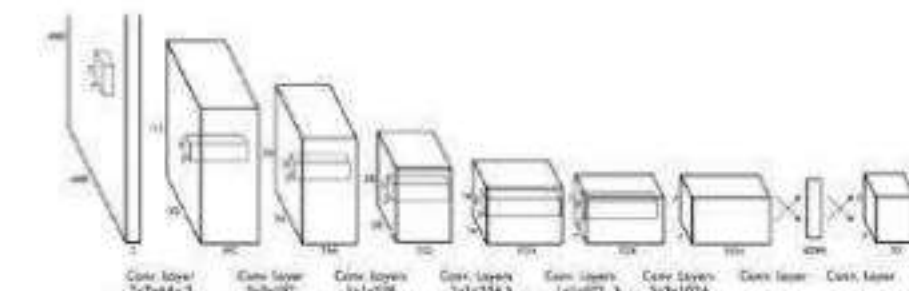

YOLO - Object Detection Algorithm

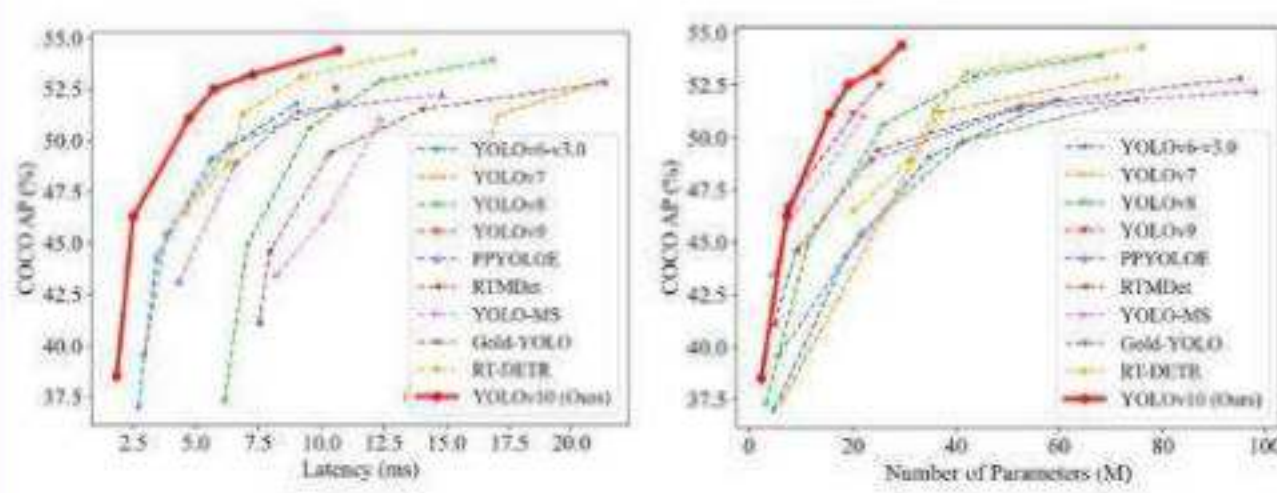

YOLOv10 Compared to Other Models

Remaining Technical Challenges

Filter Optimization: One key challenge in our workflow is optimizing the data filtering process. Currently, we use three separate filters that sort data into designated folders. While effective, this approach is computationally heavy and time-consuming, especially with large datasets. To improve efficiency, we plan to either optimize each filter's performance or combine them into a unified filter with conditional logic for accurate sorting. This optimization aims to reduce processing time significantly while enhancing data categorization accuracy, ultimately improving efficiency and scalability for larger datasets.

ML Model Accuracy Improvement: As with any machine learning application, a primary focus of using the YOLO architecture is to improve its accuracy for a given task. Several methods can be applied to enhance the model's performance, including fine-tuning hyperparameters such as learning rate, batch size, and momentum, as well as augmenting the dataset with additional annotated images to increase feature diversity. Additionally, optimizing the anchor box configuration and adjusting the model's detection layers can help improve object localization and classification accuracy. These techniques ensure the YOLO architecture is well-adapted to the specific application, delivering reliable and precise results.

Data Augmentation for Robustness: To achieve the best anticipated outcomes, another critical challenge is ensuring the model's robustness across various environmental conditions. Fortunately, we already have a diverse set of footage, including both indoor and outdoor scenes, which will be leveraged to simulate real-world variations in lighting, occlusion, and background complexity. By incorporating this existing footage into the training process, we can expose the model to a broader range of conditions, enhancing its ability to generalize to different settings. This will help improve the model's adaptability, ensuring consistent and reliable performance in both indoor and outdoor environments.

Implications for Company & Economic Impact

Successfully implementing our plan enables us to quickly develop and distribute a diverse range of innovative devices and educational materials for our extensive network of caregivers and advocates. This network includes dedicated professionals such as veterinarians and licensed rehabilitators specializing in wildlife care. By providing these essential resources, we aim to enhance the standard of care for wildlife, ensuring every animal receives the attention and support it requires to thrive, benefitting individual animals, and fostering awareness of wildlife conservation among caregivers and the broader community. Through collaboration and education, we can positively impact countless animals and contribute to preserving biodiversity.