



ON Semiconductor®

Web Based ON Semiconductor Integrated Circuit Simulation Development

onsemi.com

TECHNICAL DIRECTORS:

Robert Davis
Frank Kolanko

TEAM MEMBERS: (L to R)

Frank Kolanko
Lena Nans (E)
Alejandro Hoyos (E)



PROJECT MOTIVATION:

In the field of integrated semiconductors, a plethora of SPICE simulators exist to design and troubleshoot products before production. Unfortunately, due to the limitation of some of these simulators, issues with convergence and unacceptable simulation times often occur. Therefore, people waste a significant amount of time in the development phase downloading various simulators, designing on those simulators, and then coordinating between the buyer and the manufacturer. Any questions that arise throughout this procedure also prolong the overall development process as customers clarify their intent. At the moment, no integrated circuit manufacturer has fully implemented an online simulator to reduce the time needed for ordering semiconductor products. SystemVision, a product of Mentor Graphics, provides a cloud-based platform that can solve the aforementioned interfacing problems by providing an online schematic simulator platform capable of accurately reproducing and simulating integrated circuits. With its VHDL-AMS modeling language and its graphical user interface, the design process becomes broadly accessible to customers, designers, and manufacturers.

ANTICIPATED BEST OUTCOME:

For this capstone project, each capstone member will provide extensive support by creating fully working schematic design simulations on SystemVision. At ON Semiconductor, the baseline of the products includes: switching regulators, drivers, SMART drivers, LED drivers, and low dropout linear voltage regulators. Phase one of this project focuses on developing the simulation of a buck converter product family within the SystemVision website. In phase two, if time permits, the capstone team will provide demo boards of these products with their respective manuals for use in recruiting and promotional events.

IMPLICATIONS FOR COMPANY AND INDUSTRY:

With SystemVision's powerful simulator, ON Semiconductor could gain a significant advantage by enhancing the product design-in experience. In fact, ON Semiconductor stands to transform the way people shop for integrated circuits by streamlining the design process, saving a significant amount of time in the purchasing phase. Using cloud-based simulations, a customer will be able to remotely design products and interact with ON Semiconductor representatives instead of running simulation in two different locations. Specifically, this company will have a set of web-based buck converter models and simulation benches as a part of their pilot program with the help of this capstone team.

PROJECT OUTCOME:

The Anticipated Best Outcome was achieved.

KEY ACCOMPLISHMENTS:

Component Implementation: Mentor Graphics SystemVision provides an online platform for circuit simulation that addresses the needs of professionals, enthusiasts, and students. As a website that continues to grow and promote shared designs, our capstone team designed a mixture of digital and analog components to serve as foundational components of the final integrated circuit. Our capstone team sequentially implemented sub-circuits of the buck converter to ensure that each of them worked as expected. On a weekly basis, our team created components for a soft-start ramp, an oscillator, an error amplifier, a voltage mode regulator, and a current-mode regulator.

Design Within Specification: After verifying the performance of each subcircuit of the buck converter chip, alterations were made so that outputs better matched the ideal performance according to each respective spec sheet. Additional circuits such as a bootstrap, a saw tooth oscillator, and a gate driver were added to the buck converter simulation draft. Finally, circuit protection features such as overvoltage, and undervoltage were added to the schematics.

Supplemental Pin Simulations: Each member of the NCV8901xx buck converter family contains pins for input voltage, ground, enable, drive, bootstrap, feedback and compensation. For added functionality, the NCV890104 model has the ability to add resistors to set the modulation and depth of the switching frequency. Additional features on some models include pins that set a reset delay for regulation mode, and other models which contain pins for synchronization. Each of these additional pins were simulated for later use.

Buck Converter Simulation: Upon testing and combining each of the sub-circuits, this capstone team created top-level designs of each respective buck converter in the NCV8901xx product family with their corresponding pins and specifications.

Printed Circuit Board Schematics and Layout: Once each NCV8901xx buck converter was successfully simulated in the SystemVision environment, individual schematics were created using Orcad. A demo board was defined to highlight five members of the NCV8901xx family. The board is divided into 3 sections to highlight 3 different application features. Then, a netlist was imported to PADS where the PCB design layout began.

- Cascaded buck converters demonstrate ability to synchronize with other timers.
- Digital meters at inputs and output provide current and voltage readouts to demonstrate efficiency.
- Three device family members (each with different current capabilities) are used to supply power to 3 isolated USB ports for cell phones or other devices.

Then, a netlist was imported to PADS and PCB layout began.



ON Semiconductor®

Web Based ON Semiconductor Integrated Circuit Simulation Development

onsemi.com

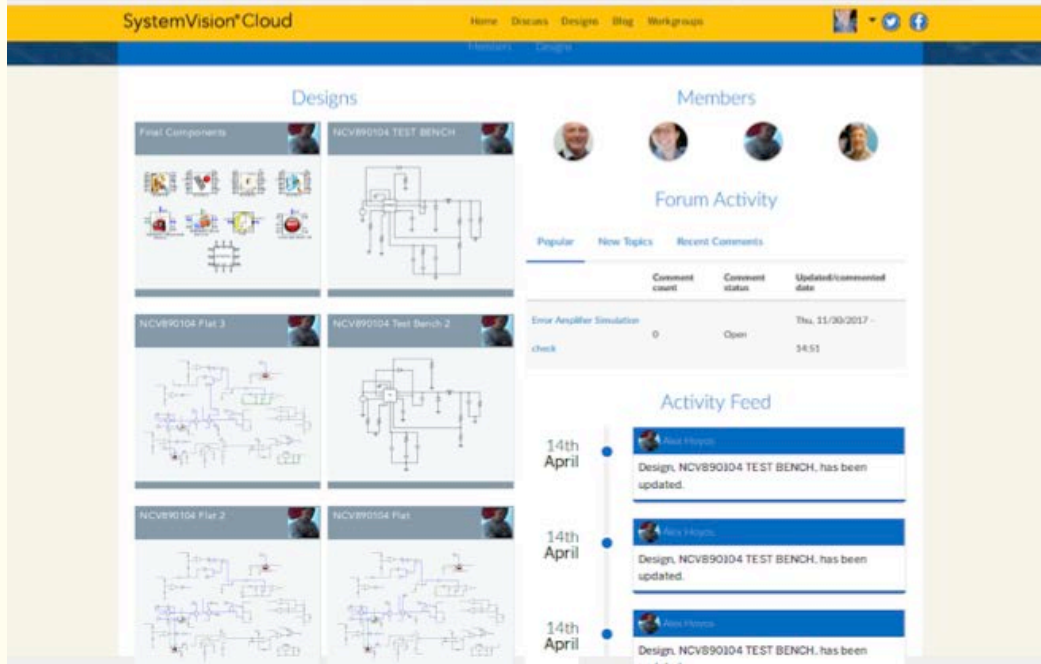

Fig 1: Screenshot of the SystemVision Development Tool; provides user with a schematic simulation environment for customers to see accurate simulations.

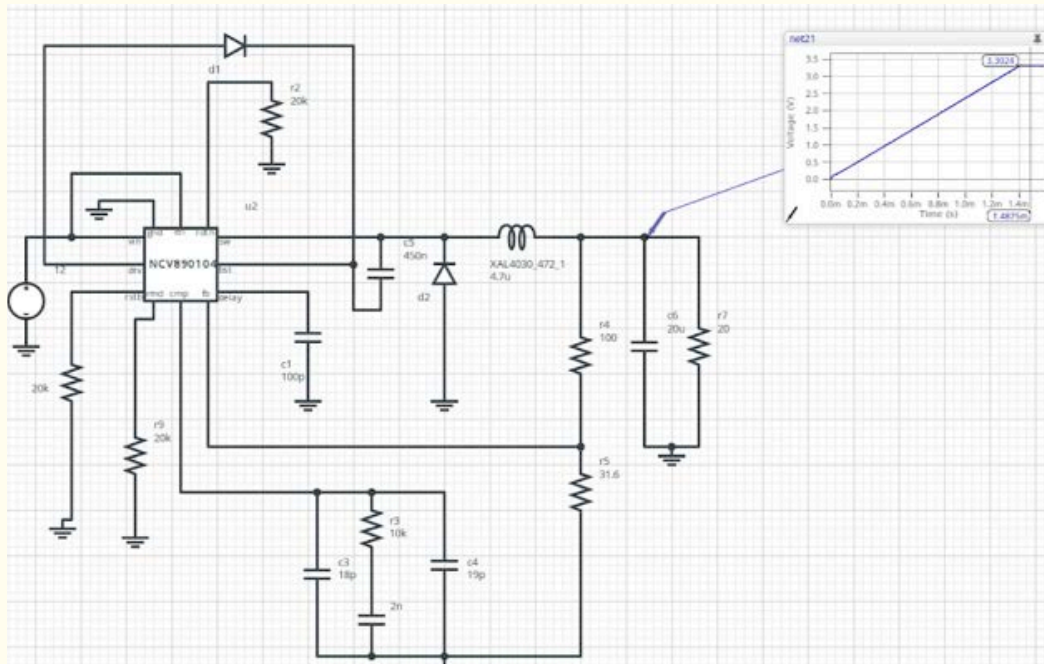

Fig 2: SystemVision online simulation implementation of NCV890104 device. The probe indicates that the simulation works as expected.

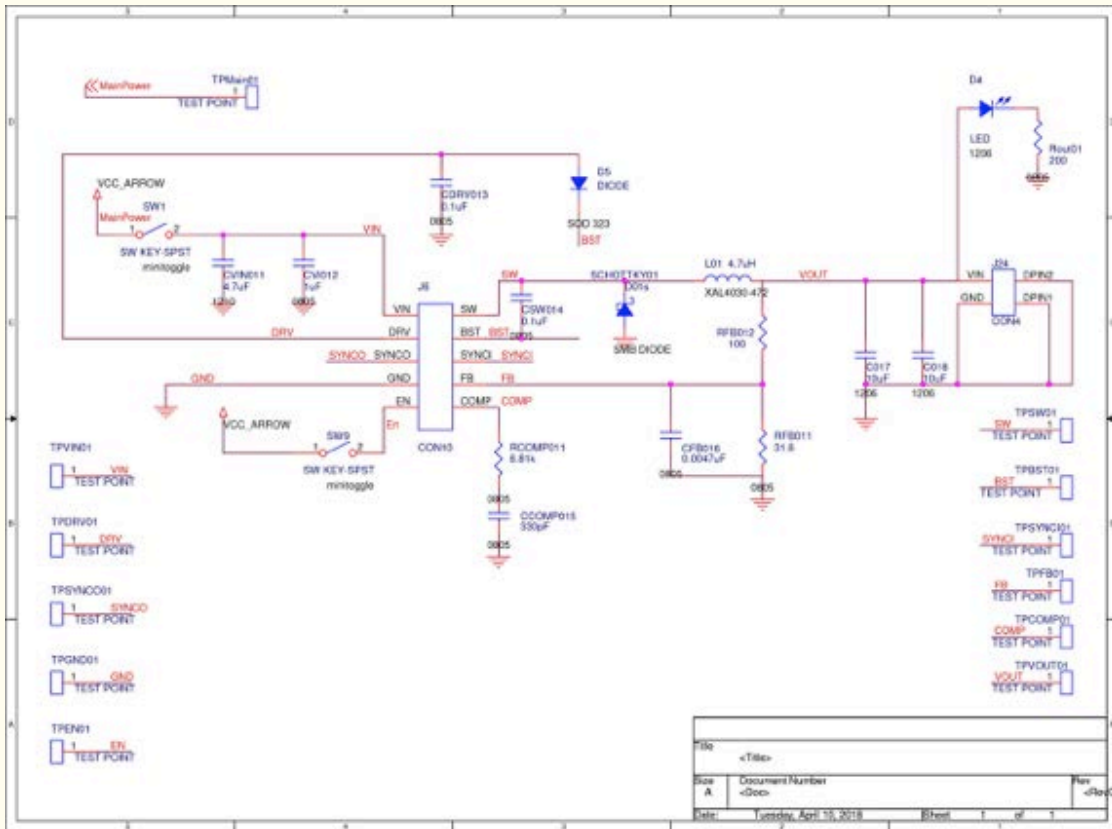

Fig 3: OrCAD schematic of for PCB layout of NCV890101 board

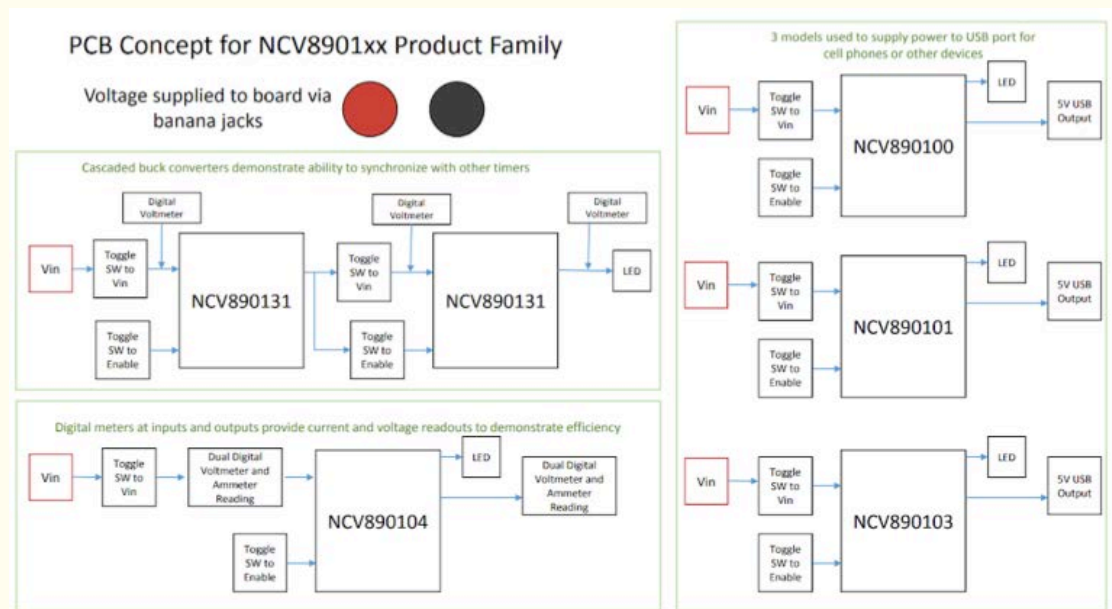

Fig 4: Block diagram of PCB functionality: This layout includes all NCV8901xx chips where three models provide a 5V supply to a handheld device. The left layouts present voltage and current readings as well as abilities to sync with another timing device.